

Programmable Controller

**MELSEC iQ-R**  
series

# MELSEC iQ-R High Speed Data Logger Module User's Manual (Startup)

---

-RD81DL96  
-SW1DNN-RDLUTL (High Speed Data Logger Module Tool)



# SAFETY PRECAUTIONS

---

(Read these precautions before using this product.)

Before using this product, please read this manual and the relevant manuals carefully and pay full attention to safety to handle the product correctly.

The precautions given in this manual are concerned with this product only. For the safety precautions for the programmable controller system, refer to the user's manual for the module used and the MELSEC iQ-R Module Configuration Manual.

In this manual, the safety precautions are classified into two levels: "⚠️ WARNING" and "⚠️ CAUTION".



## **WARNING**

Indicates that incorrect handling may cause hazardous conditions, resulting in death or severe injury.

---



## **CAUTION**

Indicates that incorrect handling may cause hazardous conditions, resulting in minor or moderate injury or property damage.

---

Under some circumstances, failure to observe the precautions given under "⚠️ CAUTION" may lead to serious consequences.

Observe the precautions of both levels because they are important for personal and system safety.

Make sure that the end users read this manual and then keep the manual in a safe place for future reference.

## [Design Precautions]

---

### **WARNING**

- Configure safety circuits external to the programmable controller to ensure that the entire system operates safely even when a fault occurs in the external power supply or the programmable controller. Failure to do so may result in an accident due to an incorrect output or malfunction.
    - (1) Emergency stop circuits, protection circuits, and protective interlock circuits for conflicting operations (such as forward/reverse rotations or upper/lower limit positioning) must be configured external to the programmable controller.
    - (2) When the programmable controller detects an abnormal condition, it stops the operation and all outputs are:
      - Turned off if the overcurrent or overvoltage protection of the power supply module is activated.
      - Held or turned off according to the parameter setting if the self-diagnostic function of the CPU module detects an error such as a watchdog timer error.
    - (3) All outputs may be turned on if an error occurs in a part, such as an I/O control part, where the CPU module cannot detect any error. To ensure safety operation in such a case, provide a safety mechanism or a fail-safe circuit external to the programmable controller. For a fail-safe circuit example, refer to "General Safety Requirements" in the MELSEC iQ-R Module Configuration Manual.
    - (4) Outputs may remain on or off due to a failure of a component such as a relay and transistor in an output circuit. Configure an external circuit for monitoring output signals that could cause a serious accident.
  - In an output circuit, when a load current exceeding the rated current or an overcurrent caused by a load short-circuit flows for a long time, it may cause smoke and fire. To prevent this, configure an external safety circuit, such as a fuse.
  - Configure a circuit so that the programmable controller is turned on first and then the external power supply. If the external power supply is turned on first, an accident may occur due to an incorrect output or malfunction.
  - For the operating status of each station after a communication failure, refer to manuals relevant to the network. Incorrect output or malfunction due to a communication failure may result in an accident.
  - When connecting an external device with a CPU module or intelligent function module to modify data of a running programmable controller, configure an interlock circuit in the program to ensure that the entire system will always operate safely. For other forms of control (such as program modification, parameter change, forced output, or operating status change) of a running programmable controller, read the relevant manuals carefully and ensure that the operation is safe before proceeding. Improper operation may damage machines or cause accidents.
  - Especially, when a remote programmable controller is controlled by an external device, immediate action cannot be taken if a problem occurs in the programmable controller due to a communication failure. To prevent this, configure an interlock circuit in the program, and determine corrective actions to be taken between the external device and CPU module in case of a communication failure.
-

## [Design Precautions]

---

### **WARNING**

- Do not write any data to the "system area" and "write-protect area" of the buffer memory in the module. Also, do not use any "use prohibited" signals as an output signal from the CPU module to each module. Doing so may cause malfunction of the programmable controller system. For the "system area", "write-protect area", and the "use prohibited" signals, refer to the user's manual for the module used.
  - If a communication cable is disconnected, the network may be unstable, resulting in a communication failure of multiple stations. Configure an interlock circuit in the program to ensure that the entire system will always operate safely even if communications fail. Incorrect output or malfunction due to a communication failure may result in an accident.
  - To maintain the safety of the programmable controller system against unauthorized access from external devices via the network, take appropriate measures. To maintain the safety against unauthorized access via the Internet, take measures such as installing a firewall.
- 

## [Design Precautions]

---

### **CAUTION**

- Do not install the control lines or communication cables together with the main circuit lines or power cables. Keep a distance of 100mm or more between them. Failure to do so may result in malfunction due to noise.
  - During control of an inductive load such as a lamp, heater, or solenoid valve, a large current (approximately ten times greater than normal) may flow when the output is turned from off to on. Therefore, use a module that has a sufficient current rating.
  - After the CPU module is powered on or is reset, the time taken to enter the RUN status varies depending on the system configuration, parameter settings, and/or program size. Design circuits so that the entire system will always operate safely, regardless of the time.
  - Do not power off the programmable controller or do not reset the CPU module while the settings are being written. Doing so will make the data in the flash ROM or SD memory card undefined. The values need to be set in the buffer memory and written to the flash ROM or the SD memory card again. Doing so may cause malfunction or failure of the module.
  - When changing the operating status of the CPU module from external devices (such as remote RUN/STOP functions), select "Do Not Open in Program" for "Open Method Setting" in the module parameters. If "Open in Program" is selected, an execution of remote STOP causes the communication line to close. Consequently, the CPU module cannot reopen the communication line, and the external device cannot execute the remote RUN.
-

## [Installation Precautions]

---

### **WARNING**

- Shut off the external power supply (all phases) used in the system before mounting or removing the module. Failure to do so may result in electric shock or cause the module to fail or malfunction.
- 

## [Installation Precautions]

---

### **CAUTION**

- Use the programmable controller in an environment that meets general specifications written in Safety Guidelines included in the base unit. Failure to do so may result in electric shock, fire, malfunction, or damage to or deterioration of the product.
  - To mount a module, place the concave part(s) located at the bottom onto the guide(s) of the base unit, and push in the module, and make sure to fix the module with screws since this module has no module fixing hook. Incorrect interconnection may cause malfunction, failure, or drop of the module.
  - Tighten the screws within the specified torque range. Undertightening can cause drop of the screw, short circuit, or malfunction. Overtightening can damage the screw and/or module, resulting in drop, short circuit, or malfunction.
  - When using an extension cable, connect it to the extension cable connector of the base unit securely. Check the connection for looseness. Poor contact may cause malfunction.
  - When using an SD memory card, fully insert it into the memory card slot. Check that it is inserted completely. Poor contact may cause malfunction.
  - Securely insert an extended SRAM cassette into the cassette connector of a CPU module. After insertion, close the cassette cover and check that the cassette is inserted completely. Poor contact may cause malfunction.
  - Do not directly touch any conductive parts and electronic components of the module, SD memory card, extended SRAM cassette, or connector. Doing so may cause malfunction or failure of the module.
- 

## [Wiring Precautions]

---

### **WARNING**

- Shut off the external power supply (all phases) used in the system before installation and wiring. Failure to do so may result in electric shock or cause the module to fail or malfunction.
  - After installation and wiring, attach the included terminal cover to the module before turning it on for operation. Failure to do so may result in electric shock.
-

## [Wiring Precautions]

---

### CAUTION

- Individually ground the FG and LG terminals of the programmable controller with a ground resistance of 100 ohms or less. Failure to do so may result in electric shock or malfunction.
  - Use applicable solderless terminals and tighten them within the specified torque range. If any spade solderless terminal is used, it may be disconnected when the terminal screw comes loose, resulting in failure.
  - Check the rated voltage and signal layout before wiring to the module, and connect the cables correctly. Connecting a power supply with a different voltage rating or incorrect wiring may cause fire or failure.
  - Connectors for external devices must be crimped or pressed with the tool specified by the manufacturer, or must be correctly soldered. Incomplete connections may cause short circuit, fire, or malfunction.
  - Securely connect the connector to the module. Poor contact may cause malfunction.
  - Do not install the control lines or communication cables together with the main circuit lines or power cables. Keep a distance of 100mm or more between them. Failure to do so may result in malfunction due to noise.
  - Place the cables in a duct or clamp them. If not, dangling cable may swing or inadvertently be pulled, resulting in damage to the module or cables or malfunction due to poor contact. Do not clamp the extension cables with the jacket stripped. Doing so may change the characteristics of the cables, resulting in malfunction.
  - Check the interface type and correctly connect the cable. Incorrect wiring (connecting the cable to an incorrect interface) may cause failure of the module and external device.
  - Tighten the terminal screws or connector screws within the specified torque range. Undertightening can cause drop of the screw, short circuit, fire, or malfunction. Overtightening can damage the screw and/or module, resulting in drop, short circuit, fire, or malfunction.
  - When disconnecting the cable from the module, do not pull the cable by the cable part. For the cable with connector, hold the connector part of the cable. For the cable connected to the terminal block, loosen the terminal screw. Pulling the cable connected to the module may result in malfunction or damage to the module or cable.
  - Prevent foreign matter such as dust or wire chips from entering the module. Such foreign matter can cause a fire, failure, or malfunction.
  - A protective film is attached to the top of the module to prevent foreign matter, such as wire chips, from entering the module during wiring. Do not remove the film during wiring. Remove it for heat dissipation before system operation.
-

## [Wiring Precautions]

---

### **CAUTION**

- Programmable controllers must be installed in control panels. Connect the main power supply to the power supply module in the control panel through a relay terminal block. Wiring and replacement of a power supply module must be performed by qualified maintenance personnel with knowledge of protection against electric shock. For wiring, refer to the MELSEC iQ-R Module Configuration Manual.
  - For Ethernet cables to be used in the system, select the ones that meet the specifications in the user's manual for the module used. If not, normal data transmission is not guaranteed.
- 

## [Startup and Maintenance Precautions]

---

### **WARNING**

- Do not touch any terminal while power is on. Doing so will cause electric shock or malfunction.
  - Correctly connect the battery connector. Do not charge, disassemble, heat, short-circuit, solder, or throw the battery into the fire. Also, do not expose it to liquid or strong shock. Doing so will cause the battery to produce heat, explode, ignite, or leak, resulting in injury or fire.
  - Shut off the external power supply (all phases) used in the system before cleaning the module or retightening the terminal screws, connector screws, or module fixing screws. Failure to do so may result in electric shock.
-



## [Startup and Maintenance Precautions]

---

### **CAUTION**

- When connecting an external device with a CPU module or intelligent function module to modify data of a running programmable controller, configure an interlock circuit in the program to ensure that the entire system will always operate safely. For other forms of control (such as program modification, parameter change, forced output, or operating status change) of a running programmable controller, read the relevant manuals carefully and ensure that the operation is safe before proceeding. Improper operation may damage machines or cause accidents.
  - Especially, when a remote programmable controller is controlled by an external device, immediate action cannot be taken if a problem occurs in the programmable controller due to a communication failure. To prevent this, configure an interlock circuit in the program, and determine corrective actions to be taken between the external device and CPU module in case of a communication failure.
  - Do not disassemble or modify the modules. Doing so may cause failure, malfunction, injury, or a fire.
  - Use any radio communication device such as a cellular phone or PHS (Personal Handy-phone System) more than 25cm away in all directions from the programmable controller. Failure to do so may cause malfunction.
  - Shut off the external power supply (all phases) used in the system before mounting or removing the module. Failure to do so may cause the module to fail or malfunction.
  - Tighten the screws within the specified torque range. Undertightening can cause drop of the component or wire, short circuit, or malfunction. Overtightening can damage the screw and/or module, resulting in drop, short circuit, or malfunction.
  - After the first use of the product, do not mount/remove the module to/from the base unit, and the terminal block to/from the module, and do not insert/remove the extended SRAM cassette to/from the CPU module more than 50 times (IEC 61131-2 compliant) respectively. Exceeding the limit may cause malfunction.
  - After the first use of the product, do not insert/remove the SD memory card to/from the CPU module more than 500 times. Exceeding the limit may cause malfunction.
  - Do not touch the metal terminals on the back side of the SD memory card. Doing so may cause malfunction or failure of the module.
  - Do not touch the integrated circuits on the circuit board of an extended SRAM cassette. Doing so may cause malfunction or failure of the module.
  - Do not drop or apply shock to the battery to be installed in the module. Doing so may damage the battery, causing the battery fluid to leak inside the battery. If the battery is dropped or any shock is applied to it, dispose of it without using.
  - Startup and maintenance of a control panel must be performed by qualified maintenance personnel with knowledge of protection against electric shock. Lock the control panel so that only qualified maintenance personnel can operate it.
-

## [Startup and Maintenance Precautions]

---

### CAUTION

- Before handling the module, touch a conducting object such as a grounded metal to discharge the static electricity from the human body. Failure to do so may cause the module to fail or malfunction.
- 

## [Operating Precautions]

---

### CAUTION

- When changing data and operating status, and modifying program of the running programmable controller from an external device such as a personal computer connected to an intelligent function module, read relevant manuals carefully and ensure the safety before operation. Incorrect change or modification may cause system malfunction, damage to the machines, or accidents.
  - Do not power off the programmable controller or reset the CPU module while the setting values in the buffer memory are being written to the flash ROM in the module. Doing so will make the data in the flash ROM or SD memory card undefined. The values need to be set in the buffer memory and written to the flash ROM or SD memory card again. Doing so can cause malfunction or failure of the module.
- 

## [Disposal Precautions]

---

### CAUTION

- When disposing of this product, treat it as industrial waste.
  - When disposing of batteries, separate them from other wastes according to the local regulations. For details on battery regulations in EU member states, refer to the MELSEC iQ-R Module Configuration Manual.
- 

## [Transportation Precautions]

---

### CAUTION

- When transporting lithium batteries, follow the transportation regulations. For details on the regulated models, refer to the MELSEC iQ-R Module Configuration Manual.
  - The halogens (such as fluorine, chlorine, bromine, and iodine), which are contained in a fumigant used for disinfection and pest control of wood packaging materials, may cause failure of the product. Prevent the entry of fumigant residues into the product or consider other methods (such as heat treatment) instead of fumigation. The disinfection and pest control measures must be applied to unprocessed raw wood.
-

# CONDITIONS OF USE FOR THE PRODUCT

---

- (1) Mitsubishi programmable controller ("the PRODUCT") shall be used in conditions;
- i) where any problem, fault or failure occurring in the PRODUCT, if any, shall not lead to any major or serious accident; and
  - ii) where the backup and fail-safe function are systematically or automatically provided outside of the PRODUCT for the case of any problem, fault or failure occurring in the PRODUCT.
- (2) The PRODUCT has been designed and manufactured for the purpose of being used in general industries. MITSUBISHI SHALL HAVE NO RESPONSIBILITY OR LIABILITY (INCLUDING, BUT NOT LIMITED TO ANY AND ALL RESPONSIBILITY OR LIABILITY BASED ON CONTRACT, WARRANTY, TORT, PRODUCT LIABILITY) FOR ANY INJURY OR DEATH TO PERSONS OR LOSS OR DAMAGE TO PROPERTY CAUSED BY the PRODUCT THAT ARE OPERATED OR USED IN APPLICATION NOT INTENDED OR EXCLUDED BY INSTRUCTIONS, PRECAUTIONS, OR WARNING CONTAINED IN MITSUBISHI'S USER, INSTRUCTION AND/OR SAFETY MANUALS, TECHNICAL BULLETINS AND GUIDELINES FOR the PRODUCT.

("Prohibited Application")

Prohibited Applications include, but not limited to, the use of the PRODUCT in;

- Nuclear Power Plants and any other power plants operated by Power companies, and/or any other cases in which the public could be affected if any problem or fault occurs in the PRODUCT.
- Railway companies or Public service purposes, and/or any other cases in which establishment of a special quality assurance system is required by the Purchaser or End User.
- Aircraft or Aerospace, Medical applications, Train equipment, transport equipment such as Elevator and Escalator, Incineration and Fuel devices, Vehicles, Manned transportation, Equipment for Recreation and Amusement, and Safety devices, handling of Nuclear or Hazardous Materials or Chemicals, Mining and Drilling, and/or other applications where there is a significant risk of injury to the public or property.

Notwithstanding the above, restrictions Mitsubishi may in its sole discretion, authorize use of the PRODUCT in one or more of the Prohibited Applications, provided that the usage of the PRODUCT is limited only for the specific applications agreed to by Mitsubishi and provided further that no special quality assurance or fail-safe, redundant or other safety features which exceed the general specifications of the PRODUCTS are required. For details, please contact the Mitsubishi representative in your region.

# CONSIDERATIONS FOR USE

---

This section explains the following considerations.

- ☞ Page 10 Considerations for network connection
- ☞ Page 10 Considerations for performance/specifications
- ☞ Page 11 Considerations for data logging, event logging, and report functions
- ☞ Page 12 Considerations for other functions
- ☞ Page 12 Considerations for accessing a high speed data logger module
- ☞ Page 13 Considerations for security
- ☞ Page 13 Considerations for using SD memory cards
- ☞ Page 15 Considerations for the recipe function

## Considerations for network connection

### ■Mail server and FTP server connections

When immediately powering ON after powering OFF, connection to mail servers or FTP servers may fail. Power the programmable controller OFF, wait several minutes then power it ON.

## Considerations for performance/specifications

### ■Sequence scan time of CPU module

When using the high speed data logger module, the CPU module sequence scan time may increase. Design your system and programs keeping in mind this increase in sequence scan time of the CPU module.

### ■Network connection using Ethernet

- When connecting to Ethernet network, basically configure the communication route to the access target via Ethernet (twisted pair) cables and hubs. Note that when accessing via wireless LAN (Wi-Fi) or router, an error such as timeout or missing data occurs, and cannot be communicated properly depending on the status of the equipment (wireless LAN or router) on the network or the access route.
- When the access to the high speed data logger module is overloaded, errors and missing data may occur. Creating logging files, report files might take time, and communication with the module might not be possible. Reduce the load on the Ethernet network which is connected to the high speed data logger module.

### ■Time handled on the high speed data logger module

Time handled on the high speed data logger module is the time on the CPU module. For errors and the optimum timing for setting the time, refer to the following section.



- ☞ Page 23 Performance Specifications
- 📖 MELSEC iQ-R High Speed Data Logger Module User's Manual(Application)

### ■High speed sampling



The high speed sampling function is not supported by CPU modules on other stations via a network.

## Considerations for data logging, event logging, and report functions



### ■Data logging, event logging, and report functions

- The data logging, event logging, and report functions are best effort functions. Since the processing time of a module varies depending on the setting and the status of other devices, these functions may not perform at the set sampling interval. Run the system by fully verifying the processing time of each function when constructing it. For processing time, refer to the following manual.  
(MELSEC iQ-R High Speed Data Logger Module User's Manual(Application))
- If data logging function, event logging function, or report function are used, they affect the sequence scan time of the access target CPU module. Run the system by verifying how the sequence scan time is affected when configuring the system.  
(MELSEC iQ-R High Speed Data Logger Module User's Manual(Application))
- If exponential format is selected for the data output format with the data logging, event logging, or report setting, rounding errors will occur in the range of the number of digits that exceed the number of digits set for the decimal part.
- If the result of the linear function transformation with the scaling function exceeds the maximum or minimum range of the specified output format, the maximum or minimum value will be output in binary format. Therefore, when outputting in the binary format, errors may occur in the output values.
- The file transfer/e-mail transmission via the file transfer function/e-mail function may take from a few seconds to tens of seconds depending on the network line or transmission size. Target files may be deleted before file transfer/e-mail transmission completes depending on the settings. Review the file switching timing and the number of files saved setting and lengthen the time until the file is deleted.  
(MELSEC iQ-R High Speed Data Logger Module User's Manual(Application))
- When a CSV file is opened with Excel, the date column format is displayed in the default setting of Excel. Set the cell format as necessary.
- Since general sampling specified data and report current value data are sampled asynchronously with the sequence scan, data separation may occur. If data separation must be prevented, set the number of device points sampled at one time to less than the access units, or set the module to use high speed sampling.

### ■Data logging function

- When the number of device points to be sampled by the trigger logging function exceeds the access units and general sampling is specified for the data sampling method, device values sampled in another sequence scan as the one where the trigger occurred may be included in one data row. To avoid this, the number of device points that can be sampled at once should be less than the access units or high speed sampling should be used. For the access units, refer to the following:  
( Page 41 Access units)
- Immediately after switching the programmable controller system ON, if a trigger occurs before sampling the number of lines of data before the trigger, the data before the trigger may be a few lines less than the specified amount.
- When triggers continuously occur with the trigger logging function, triggers may not be detected or the number of lines of data specified before the trigger may not be output. For operation when triggers continuously occur, refer to the following manual.  
(MELSEC iQ-R High Speed Data Logger Module User's Manual(Application))

### ■Report function

- Immediately after switching the programmable controller system ON, if a creation trigger occurs when data does not exist in the data logging file, an error occurs in the high speed data logger module. Configure and construct the system so that the creation trigger occurs after data is saved in the data logging file.
- Report output takes time. Therefore, according to the data logging save setting, the data logging file including the data when the creation trigger occurs, may be deleted before the report output is completed. In this situation, the data for the specified number of records are not output, and an error occurs in the high speed data logger module. Check the Point in the following manual when configuring and constructing the system.  
(MELSEC iQ-R High Speed Data Logger Module User's Manual(Application))
- When the creation triggers continuously occurred, they may not be detected. For operation when the creation trigger continuously occurred, refer to the following manual.  
(MELSEC iQ-R High Speed Data Logger Module User's Manual(Application))

- When using Microsoft Excel 2010 (32-bit version), Microsoft Excel 2013 (32-bit version), or Microsoft Excel 2016 (32-bit version), install Visual Basic® for Applications (abbreviated as VBA below). If VBA is not installed, the error message below is displayed when the "Layout setting" screen is started, and layout settings cannot be configured.  
"This workbook has lost its VBA Project, ActiveX Controls and any other programmability-related features."
- The saving format of a report file output by the report function is the xls format. Some of the functions added to Microsoft Excel 2007 and later cannot be used.
- Microsoft Excel 2010 (64-bit version) is not supported.
- Microsoft Excel 2013 (64-bit version) is not supported.
- Microsoft Excel 2016 (64-bit version) is not supported.

## Considerations for other functions

### ■ Access target CPU setting

- When rewriting the configuration tool settings, turning the power OFF to ON, or resetting the CPU module, the high speed data logger module is prepared to communicate with the access target CPU module. Therefore, if a large number of access target CPU modules are set, several minutes are required for this preparation.
- The following conditions may affect the general sampling, file transfer function, and e-mail function: when the CPU module which does not exist in the access target CPU module is set, or the high speed data logger module cannot communicate with the access target CPU module temporary because of the power interruption of access target CPU module or network failure. Use the high speed data logger modules with the status that can communicate with the CPU module set as access target CPU module.

### ■ Time synchronization function

- If implementing the time synchronization with the CPU module, it will change the time of the high speed data logger module. When the CPU module's time is changed, the high speed data logger module's time may be greatly changed.
- Since there is inaccuracy in the clock element of the CPU module and the high speed data logger module, the time may be moved slightly forward or backward when the time is synchronized. Since changing the time of the high speed data logger module affects the time stamp, as well as the following determination of the cycles and of the time: data logging, event logging, and reports, configure the module to synchronize its time at the required minimum range.

## Considerations for accessing a high speed data logger module

### ■ Web browser operations and settings

- In the local area network (LAN) setting of the Web browser, do not set a proxy server for the local address.  
( Page 53 Online startup)

### ■ FTP server function

- Because of FTP client side application restrictions, if the user name or password is input incorrectly, end the FTP operation and redo the FTP connection from the beginning. FTP may not operate correctly by reentering the correct user name or password with the 'user' FTP command.
- The maximum number of simultaneous connections to the FTP server is 10. However, depending on the FTP client, it may make multiple simultaneous connections, so an FTP client may not be able to login even if 10 clients are not connected. In this situation, shutdown all the FTP clients, then restart and connect them.
- When transferring many files at once with FTP, a 426 error (data connection error) may occur. In this situation, split the files into multiple parts then transfer them separately.
- When Internet Explorer is used for FTP access, the user authentication screen may not be displayed due to the Internet Explorer specification. In such a case, enter the high speed data logger module's address in the following format.  
ftp://<user name>:<password>@<high speed data logger module's address or hostname>/

- When Internet Explorer is used for FTP access, data logging files, event logging files, report files, and recipe files may not open directly due to the Internet Explorer specification. Make sure to open the files after saving them to a personal computer.
- When Internet Explorer is used for FTP access, due to the Internet Explorer specification, errors may not be displayed even if the transfer failed when files are transferred to the SD memory card which does not have enough free space. Update the display and check if the files are transferred normally.
- When Internet Explorer is used for FTP access, a retry is performed at user authentication failure due to the Internet Explorer specification. Note that unintentional repeated entry of wrong passwords may lock the module.

### ■Connecting GX LogViewer

- The maximum number of connections for GX LogViewer to access the high speed data logger modules simultaneously is 2.

### ■Connecting configuration tools

- Note that the module may be in an unintended status when operating it from multiple configuration tools at the same time.

## Considerations for security

- Although the high speed data logger module supports basic authentication (account setting) using user names and passwords, it does not completely protect the system from illegal access. Avoid accounts (user name, password) consisting of simple alphanumeric characters only, and include some non-alphanumeric characters (\$, &, ?) to create a complicated user name and password.

## Considerations for using SD memory cards

### ■SD memory card file/directory

- Do not create files (excluding module operating files and recipe files) or folders on the SD memory card with a personal computer. If files or folders are created on the SD memory card with a personal computer, they may be deleted.

### ■SD memory card to be used

- Use SD memory cards manufactured by Mitsubishi Electric Corporation. If any other SD memory cards are used, a failure such as data corruption on the SD memory card or a system shutdown (module major error (error code: 2450H) occurs in the CPU module) may occur during an operation. (  Page 71 Connection System Equipment)

### ■When turning OFF or resetting the CPU module

- When a CPU module is powered OFF or reset while writing data to an SD memory card, the processing to write data to the SD memory card may not be completed. It may cause a loss of logging data during the processing, corruption of data in the SD memory card that is being accessed, or occurrence of a file system error. The file is automatically recovered when the high speed data logger module is powered ON again, but it will not succeed in some cases.

The operation, powering OFF or resetting the CPU module after stopping file access, should be considered. For the important data, a periodic backup is recommended.

(  Page 65 File access stop processing method)

### ■When removing or replacing the SD memory card

- Make sure to stop file access before removing or replacing the SD memory card.  
(☞ Page 65 File access stop processing method)
- Not following the procedure may cause a loss of logging data during processing, corruption of data in the SD memory card that is being accessed, a file system error, or false recognition of the mounting status of the SD memory card.  
(☞ Page 63 Operations for removing and reinserting SD memory card)
- If an error occurs on the SD memory card, refer to the following manual.  
(📖 MELSEC iQ-R High Speed Data Logger Module User's Manual(Application))
- High speed data logger module settings are saved to the SD memory card. Therefore, the high speed data logger module's IP address returns to the initial status (192.168.3.3) when the SD memory card is not inserted in the module or when the power is turned OFF to ON or the CPU module is reset, without the settings written to the SD memory card. When necessary, read the current settings before removing the SD memory card and after replacing the card, promptly write those settings to the new card.

### ■SD memory card capacity

- Access speed to the SD memory card is affected by the amount of saved files. In particular, access speed becomes extremely slow when files are saved up to the capacity limit of the SD memory card. Use the SD memory card maintaining 10% or more free space on the card.
- A minimum size occupied by the files on the hard disk varies depending on the SD memory card capacity. Therefore, the actual file size and the occupied file size on the hard disk may differ.

### ■SD memory card diagnostic time

- The high speed data logger module performs diagnostics (file recovery, etc.) of the inserted SD memory card contents at the times listed below.  
When powering OFF to ON or resetting the CPU module  
When inserting an SD memory card while the power is ON
- The SD memory card diagnostic time takes longer when there are more files on the card. 100 files takes approximately 5 seconds, and 1000 files takes approximately 10 seconds.
- When many files are saved on the SD memory card, the following operations require longer time. Delete unnecessary files.  
'SD memory card status' (X1) startup time  
Time before the high speed data logger module can start processing ('Module READY' (X0) or 'Module operating status' (X5) startup time)

### ■Formatting SD memory card

- Use the format function of the configuration tool to format an SD memory card.
- Do not format an SD memory card using the format function of Windows.
- Do not reset the control CPU or turn the power OFF when formatting an SD memory card.
- High speed data logger module settings are saved to an SD memory card. Therefore, all settings are lost when formatting the SD memory card. When necessary, read the current settings before formatting, and promptly write those settings after formatting. The IP address of the high speed data logger module returns to the initial status (192.168.3.3) when turning the power OFF to ON or when resetting the module without writing the settings to the SD memory card.



### ■SD memory card life span (Limit on writing)

- An SD memory card has a limited life span (limit on writing). For details, refer to the following manual.  
(MELSEC iQ-R High Speed Data Logger Module User's Manual(Application))

### ■RECIPE folder

- The maximum number of recipe files that can be stored in the RECIPE folder is 256. Storing large numbers of files in the RECIPE folder causes a longer processing time for the following operations. Delete unnecessary files.
  - Displaying or operating the file browser
  - Displaying a file list of recipe execution operation
  - Recipe execution operation
- Do not store any files other than recipe files in the RECIPE folder.

### ■Write protect switch

- Make sure that the write protect switch of the memory card is in the unlocked position. When the write protect switch is in the locked position, no file can not be written on the SD memory card.

## Considerations for the recipe function

### ■Recipe files

- For recipe file names, use the characters usable in file names and folder (directory) names only.

### ■Recipe execution operation

- Before performing the recipe execution operation, write the high speed data logger module settings using the configuration tool, then set the module operating status to "In operation". The module operating status can be checked on the "Module Diagnostic" screen.  
(MELSEC iQ-R High Speed Data Logger Module User's Manual(Application))
- The recipe execution operation can be performed to the control CPU only. It cannot be performed to a CPU module on another station.
- Do not power OFF or reset the CPU module during the recipe execution operation. The recipe file being edited may be damaged. Power OFF or reset the CPU module after confirming the completion of the recipe execution operation.

# INTRODUCTION

---

Thank you for purchasing the Mitsubishi MELSEC iQ-R series programmable controllers.

This manual describes the performance specifications, procedures up to operation, wiring, and operation examples to use the module listed below.

Before using the product, please read this manual and relevant manuals carefully and develop familiarity with the performance of MELSEC iQ-R series programmable controller to handle the product correctly.

When applying the example programs provided in this manual to an actual system, ensure the applicability and confirm that it will not cause system control problems.

Please make sure that the end users read this manual.

## Point

The program examples shown in this manual are the examples in which the high speed data logger module (RD81DL96) is assigned to the input/output No. X/Y0 to X/Y1F unless otherwise specified. To use the program examples shown in this manual, the input/output number assignment is required. For details on the assignment of input/output number, refer to the following manual.

 MELSEC iQ-R Module Configuration Manual

---

## Relevant product



RD81DL96

# COMPLIANCE WITH EMC AND LOW VOLTAGE DIRECTIVES

---

## Method of ensuring compliance



To ensure that Mitsubishi programmable controllers maintain EMC and Low Voltage Directives when incorporated into other machinery or equipment, certain measures may be necessary. Please refer to one of the following manuals.

-  MELSEC iQ-R Module Configuration Manual
-  Safety Guideline (included in Base unit)

The CE mark on the side of the programmable controller indicates compliance with EMC and Low Voltage Directives.

## Additional measures

To ensure that this product maintains EMC and Low Voltage Directives, please refer to one of the following manuals.

-  MELSEC iQ-R Module Configuration Manual
-  Safety Guideline (included in Base unit)

# CONTENTS

|  |           |
|--|-----------|
| SAFETY PRECAUTIONS .....   | 1         |
| CONDITIONS OF USE FOR THE PRODUCT .....                                | 9         |
| CONSIDERATIONS FOR USE .....   | 10        |
| INTRODUCTION .....   | 16        |
| COMPLIANCE WITH EMC AND LOW VOLTAGE DIRECTIVES .....                   | 16        |
| RELEVANT MANUALS .....   | 19        |
| TERMS .....  | 20        |
| <b>CHAPTER 1 PART NAMES</b> .....                                      | <b>21</b> |
| <b>CHAPTER 2 SPECIFICATIONS</b> .....                                  | <b>23</b> |
| <b>2.1 Performance Specifications</b> .....                            | <b>23</b> |
| Transmission and interface specifications .....                        | 23        |
| Functional specifications .....  | 24        |
| <b>2.2 Access Specifications for a CPU Module</b> .....                | <b>33</b> |
| Accessible CPU modules .....   | 33        |
| Accessible routes .....  | 34        |
| Accessible devices .....   | 38        |
| Bit specification/digit specification of devices .....                 | 40        |
| Device specification with labels/comments .....                        | 41        |
| Access units .....   | 41        |
| <b>2.3 File Structure</b> .....  | <b>42</b> |
| Folder structure of the SD memory card .....                           | 42        |
| Folder structure at the time of file transfer .....                    | 43        |
| <b>2.4 Range of Values per Output Format</b> .....                     | <b>45</b> |
| <b>CHAPTER 3 FUNCTION LIST</b> .....                                   | <b>46</b> |
| <b>3.1 Function List of a High Speed Data Logger Module</b> .....      | <b>46</b> |
| <b>3.2 Function List of Configuration Tool</b> .....                   | <b>47</b> |
| <b>CHAPTER 4 PROCEDURES PRIOR TO OPERATION</b> .....                   | <b>49</b> |
| <b>4.1 Start up of High Speed Data Logger Module</b> .....             | <b>49</b> |
| Procedure to operate by installing the configuration tool .....        | 49        |
| Procedure to operate without installing the configuration tool .....   | 50        |
| Configuration tool .....   | 52        |
| Parameter settings .....   | 60        |
| <b>4.2 SD Memory Card</b> .....  | <b>62</b> |
| Operations for inserting SD memory card .....                          | 62        |
| Operations for removing and reinserting SD memory card .....           | 63        |
| Operations for replacing new SD memory card .....                      | 64        |
| File access stop processing method .....                               | 65        |
| SD memory card insertion/removal method .....                          | 66        |
| <b>CHAPTER 5 SYSTEM CONFIGURATION</b> .....                            | <b>67</b> |
| <b>5.1 System Configuration</b> .....                                  | <b>67</b> |
| Overall system configuration .....                                     | 67        |
| Software configuration of the high speed data logger module tool ..... | 68        |
| System configuration when installing .....                             | 68        |

|   |            |
|---|------------|
| System configuration for the initial setup, maintenance, and inspection . . . . . | 68         |
| System configuration during operation . . . . .                                   | 69         |
| <b>5.2 Connection System Equipment . . . . .</b>                                  | <b>71</b>  |
| <b>5.3 Operating Environment . . . . .</b>  | <b>72</b>  |
| <b>5.4 Considerations for System Configuration . . . . .</b>                      | <b>73</b>  |
| Considerations for using C Controller module . . . . .                            | 73         |
| <b>5.5 Supported Software Packages . . . . .</b>                                  | <b>74</b>  |
| <br>  |            |
| <b>CHAPTER 6 WIRING . . . . .</b>   | <b>75</b>  |
| <hr/>   |            |
| <b>6.1 Wiring of an Ethernet cable . . . . .</b>                                  | <b>75</b>  |
| <b>6.2 Wiring considerations . . . . .</b>  | <b>76</b>  |
| <br>  |            |
| <b>CHAPTER 7 INSTALLATION AND UNINSTALLATION . . . . .</b>                        | <b>77</b>  |
| <hr/>   |            |
| <b>7.1 Installation Procedure . . . . .</b>                                       | <b>77</b>  |
| Environment after installation . . . . .  | 77         |
| <b>7.2 Uninstallation Procedure . . . . .</b>                                     | <b>77</b>  |
| Environment after uninstallation . . . . .  | 77         |
| <br>  |            |
| <b>CHAPTER 8 OPERATION EXAMPLE . . . . .</b>                                      | <b>79</b>  |
| <hr/>   |            |
| <b>8.1 Preparing for Operation . . . . .</b>                                      | <b>79</b>  |
| Preparing equipment . . . . .   | 79         |
| System construction . . . . .   | 80         |
| <b>8.2 Logging Data before and after Trigger Occurrence . . . . .</b>             | <b>81</b>  |
| Equipment figure . . . . .  | 81         |
| Operation flow . . . . .  | 81         |
| Data logging settings (trigger logging) . . . . .                                 | 82         |
| Write settings . . . . .  | 88         |
| Graphical display of data . . . . .   | 90         |
| <b>8.3 Creating Reports from Continuously Logged Data . . . . .</b>               | <b>93</b>  |
| Equipment figure . . . . .  | 93         |
| Operation flow . . . . .  | 93         |
| Data logging settings (continuous logging) . . . . .                              | 94         |
| Report settings . . . . .   | 100        |
| Write settings . . . . .  | 109        |
| Checking created report . . . . .   | 111        |
| <br>  |            |
| <b>APPENDIX . . . . .</b>   | <b>114</b> |
| <hr/>   |            |
| <b>Appendix 1 External Dimensions . . . . .</b>                                   | <b>114</b> |
| <br>  |            |
| <b>INDEX . . . . .</b>  | <b>116</b> |
| <hr/>   |            |
| REVISIONS . . . . .   | 118        |
| WARRANTY . . . . .  | 119        |
| TRADEMARKS . . . . .  | 120        |

# RELEVANT MANUALS

| Manual name [manual number]   | Description   | Available form                |
|---|---|-------------------------------|
| MELSEC iQ-R High Speed Data Logger Module User's Manual(Startup) [SH-081561ENG] (this manual) | Specifications, procedures before operation, wiring, and operation examples of high speed data logger modules.                      | Print book<br>e-Manual<br>PDF |
| MELSEC iQ-R High Speed Data Logger Module User's Manual(Application) [SH-081562ENG]           | Functions, configuration tool, parameter setting, troubleshooting, I/O signal, and buffer memory of high speed data logger modules. | Print book<br>e-Manual<br>PDF |

This manual does not include detailed information on the following:

- General specifications
- Applicable CPU modules and the number of mountable modules
- Applicable remote head modules and the number of mountable modules
- Installation

For details, refer to the following manual.

 MELSEC iQ-R Module Configuration Manual

## Point

e-Manual refers to the Mitsubishi FA electronic book manuals that can be browsed using a dedicated tool.

e-Manual has the following features:

- Required information can be cross-searched in multiple manuals.
- Other manuals can be accessed from the links in the manual.
- Hardware specifications of each part can be found from the product figures.
- Pages that users often browse can be bookmarked.
- Sample programs can be copied to an engineering tool.

# TERMS

Unless otherwise specified, this manual uses the following terms.

| Term                               | Description  |
|------------------------------------|--|
| Account                            | A right to use a high speed data logger module or an ID necessary when using the module.   |
| Auto logging                       | A function to automatically start logging when a SD memory card with the auto logging settings written to it in advance is inserted in a running high speed data logger module.  |
| Configuration tool                 | An abbreviation for MELSEC iQ-R High Speed Data Logger Module Configuration Tool. This tool configures and maintains the high speed data logger module.  |
| Data logging                       | A function to log CPU module device values at the specified data sampling interval.  |
| Data logging file                  | A file where the data sampled by the high speed data logger module is saved in the format specified with the configuration tool.   |
| Engineering tool                   | A tool for setting, programming, debugging, and maintaining programmable controllers. For the supported tools, refer to the following manual.<br> MELSEC iQ-R Module Configuration Manual |
| Event logging                      | A function to monitor device values sampled by a CPU module and to log occurred events.  |
| Event logging file                 | A file where the events sampled by a high speed data logger module are saved in the format specified with the configuration tool.  |
| GX LogViewer                       | An abbreviation for GX LogViewer Version 1.  |
| High speed data logger module      | An abbreviation for MELSEC iQ-R series-compatible RD81DL96 high speed data logger module.  |
| High speed data logger module tool | An abbreviation for the high speed data logger module tool (SW1DNN-RDLUTL).  |
| LCPU                               | A generic term for MELSEC-L series CPU module.   |
| Logging file                       | A generic term for the data logging file and event logging file.   |
| POP before SMTP                    | One type of authorization method specified when sending e-mail. By accessing the specified POP3 server in advance before sending an e-mail, this method grants permission to use the SMTP server.  |
| QCPU (Q mode)                      | A generic term for the MELSEC-Q series CPU modules and MELSEC-Q series C Controller modules.   |
| RCPU                               | A generic term for the MELSEC iQ-R series CPU modules and MELSEC iQ-R series C Controller modules.   |
| RnENCPU                            | A generic term for R04ENCPU, R08ENCPU, R16ENCPU, R32ENCPU, and R120ENCPU.  |
| SMTP-Auth                          | One type of authorization method specified when sending e-mail. The user's account and password are authenticated between the SMTP server and user, and this method sends e-mail only if they are authenticated.   |
| Windows 8 or later                 | A generic term for Windows 8, Windows 8.1, and Windows 10.   |

# 1 PART NAMES

This chapter shows the part names of a high speed data logger module.

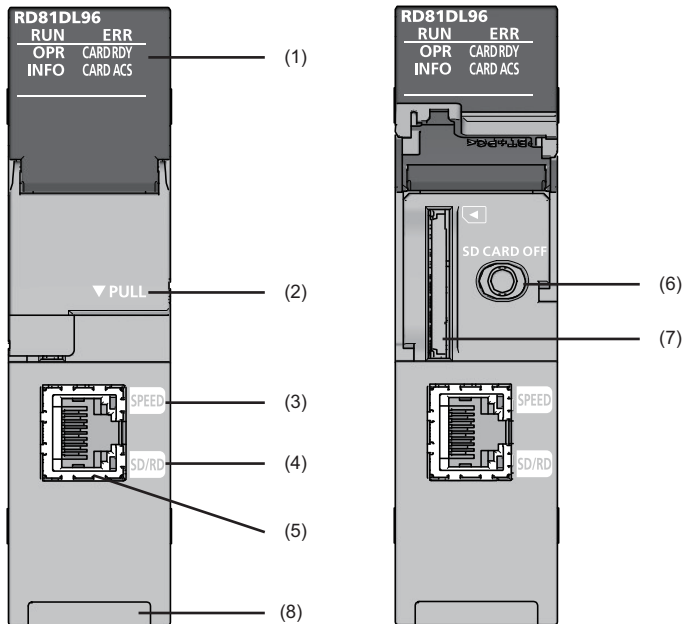

| No. | Name         | Description   |
|-----|--------------|---|
| (1) | RUN LED      | Indicates the operating status.<br><ul style="list-style-type: none"> <li>• ON: In operation</li> <li>• Flashing: Checking module, selecting the module for online module change (Flashes for 10 seconds in "Checking module" when the [Checking module] button is pressed on the "Find High Speed Data Logger Module" screen of the configuration tool.)</li> <li>• OFF: Watchdog timer error (hardware failure), module replacement allowed in the process of the online module change</li> </ul> |
|     | ERR LED      | Indicates the error status.<br><ul style="list-style-type: none"> <li>• ON: Minor error occurring/WDT error occurring (hardware error)</li> <li>• Flashing: Moderate error or major error</li> <li>• OFF: In normal status</li> </ul>   |
|     | OPR LED      | Indicates the module status.<br><ul style="list-style-type: none"> <li>• ON: Module operating status is in operation</li> <li>• Flashing: Module operating status is initializing (update settings, etc.) and stopping</li> <li>• OFF: Module operating status is stopped</li> </ul>  |
|     | INFO LED     | Indicates every information.<br><ul style="list-style-type: none"> <li>• ON: Warning</li> <li>• OFF: In normal status</li> </ul>  |
|     | CARD RDY LED | Indicates the availability of the SD memory card.<br><ul style="list-style-type: none"> <li>• ON: SD memory card accessible status (mounted status)</li> <li>• Flashing: SD memory card mounting/unmounting</li> <li>• OFF: SD memory card inaccessible status (not installed/Unmounted)</li> </ul>   |
|     | CARD ACS LED | Indicates the access status of the SD memory card.<br><ul style="list-style-type: none"> <li>• ON: Accessing SD memory card</li> <li>• OFF: SD memory card not accessed</li> </ul>  |
| (2) | Slot cover   | A cover of the SD memory card slot and the SD memory card lock switch.<br>Open this cover to insert/remove an SD memory card or to operate the switch.<br>Close the cover unless inserting/removing an SD memory card or operating the switch to prevent foreign material intrusion such as dust.   |
| (3) | SPEED LED    | Indicates the communication speed and the link status for Ethernet.<br><ul style="list-style-type: none"> <li>• ON (orange): Linking-up (1000 Mbps)</li> <li>• Flashing (green): Linking-up (100 Mbps)</li> <li>• OFF: Linking-down or linking-up (10 Mbps)</li> </ul>  |
| (4) | SD/RD LED    | Indicates the data sending/receiving status for Ethernet.<br><ul style="list-style-type: none"> <li>• ON: Sending/receiving data</li> <li>• OFF: No data sending/reception</li> </ul>   |

| No. | Name  | Description   |
|-----|---|---|
| (5) | Ethernet port                                   | A port for connecting a high speed data logger module to 10BASE-T/100BASE-TX/1000BASE-T (High speed data logger modules distinguish among 10BASE-T, 100BASE-TX, and 1000BASE-T according to an external device.)  |
| (6) | SD memory card lock switch (SD CARD OFF button) | A switch for disabling access to an SD memory card to remove it.<br>Removing an SD memory card is prohibited while the CARD RDY LED is ON or flashing.<br>For inserting and removing an SD memory card, refer to the following section.<br> Page 62 SD Memory Card |
| (7) | SD memory card slot                             | A slot to insert an SD memory card.   |
| (8) | Product information marking                     | Displays the product information (16 digits) of the module.   |

### Point

- When checking the module at online module change, the RUN LED of the high speed data logger module and the READY LED of the CPU module flash for more than 10 seconds at the same time.  
Make sure to check not only the RUN LED also the READY LED of the CPU module.
- The cause of the INFO LED lightning can be checked with the INFO LED information on the "Module Diagnostics" screen or buffer memory. Check the cause of LED lightning and take corrective actions.  
( MELSEC iQ-R High Speed Data Logger Module User's Manual(Application))



# 2 SPECIFICATIONS

This chapter explains the specifications of a high speed data logger module.

## 2.1 Performance Specifications

This section shows the performance specifications of a high speed data logger module.

### Transmission and interface specifications

| Item                               | Specification   |   |                  |                  |
|------------------------------------|---|---|------------------|------------------|
| Ethernet                           | Interface   | 1000BASE-T  | 100BASE-TX       | 10BASE-T         |
|                                    | Data transmission rate  | 1 Gbps  | 100 Mbps         | 10 Mbps          |
|                                    | Transmission method   | Base band   |                  |                  |
|                                    | Number of cascade connections<br>(When using a repeater hub)  | —   | Maximum 2 levels | Maximum 4 levels |
|                                    | Maximum segment length  | 100 m (length between a hub and a node)   |                  |                  |
|                                    | Supported function  | Auto-negotiation (automatic recognition of the communication speed/communication method)<br>Auto-MDI/MDI-X (automatic recognition of a straight/crossing cable) |                  |                  |
|                                    | IP version  | IPv4 supported  |                  |                  |
| SD memory card slot                | Supply power voltage  | 3.3 VDC   |                  |                  |
|                                    | Supply power capacity   | Up to 200 mA  |                  |                  |
|                                    | Interface   | SD memory card/SDHC memory card   |                  |                  |
|                                    | Number of insertable cards  | 1 card  |                  |                  |
| Number of occupied I/O points      | 32 points (I/O assignment: Intelligent 32 points)   |   |                  |                  |
| Clock                              | Acquired from a CPU module (CPU No.1 in a multiple CPU system).<br>Time accuracy after obtaining the time, daily error of $\pm 9.504$ seconds |   |                  |                  |
| 5 VDC internal current consumption | 1.1 A   |   |                  |                  |
| External dimensions                | Height  | 106 mm  |                  |                  |
|                                    | Width   | 27.8 mm   |                  |                  |
|                                    | Depth   | 110 mm  |                  |                  |
| Weight                             | 0.24 kg   |   |                  |                  |

# Functional specifications

## Data sampling performance specifications

The following table lists the specifications for the data sampling used for the data logging function, the event logging function, and the report function.

| Item  |   | Specifications  |  |
|---|---|---|--|
| Data sampling   | Number of access target CPUs                        | Maximum 64 CPUs   |  |
|   | Sampling interval                                   | High speed sampling   | <ul style="list-style-type: none"> <li>• Sequence scan time synchronization</li> <li>• 0.5 to 0.9 milliseconds, 1 to 32767 milliseconds (for trigger logging)</li> <li>• 2 to 32767 milliseconds (for continuous logging)</li> </ul>   |
|   |   | General sampling  | <ul style="list-style-type: none"> <li>• 0.1 to 0.9 seconds, 1 to 32767 seconds</li> <li>• Time interval specification (specify hour/minute/second)</li> </ul>   |
|   | Number of units of sampled data <sup>*1,*2,*3</sup> | High speed sampling   | Total number of units of data: 32768 (per setting: 1024)<br>Total number of device points: 32768 <sup>*4,*5</sup> (per setting: 4096)  |
|   |   | General sampling  | Total number of units of data: 65536 (per setting: 1024)<br>Total number of device points: 262144 (per setting: 4096)  |
|   | Data type <sup>*6</sup>                             |   | <ul style="list-style-type: none"> <li>• Bit</li> <li>• Word [Signed]</li> <li>• Double Word [Signed]</li> <li>• Word [Unsigned]/Bit String [16-bit]</li> <li>• Double Word [Unsigned]/Bit String [32-bit]</li> <li>• FLOAT [Single Precision]</li> <li>• FLOAT [Double Precision]</li> <li>• 16bit BCD</li> <li>• 32bit BCD</li> <li>• String: 1 to 8192 characters<sup>*7</sup></li> <li>• Raw: 1 to 8192 bytes</li> </ul> |
| Data output format <sup>*8</sup><br>(Unicode text file, CSV file) |   | <ul style="list-style-type: none"> <li>• Bit</li> <li>• Decimal format: 0 to 14 digits after the decimal point</li> <li>• Exponential format: 0 to 14 digits after the decimal point</li> <li>• Hexadecimal format</li> <li>• String</li> <li>• Raw</li> </ul> <p>■For trigger logging (output only one line after triggering), following conditions can be specified.</p> <ul style="list-style-type: none"> <li>• Time/Total time<br/>Decimal format: 0 to 4 digits after the decimal point</li> <li>• Count/Total count<br/>Decimal format: 0 digit after the decimal point</li> </ul> |  |
| Scaling <sup>*9</sup>   |   | Basic arithmetic operations: calculations combining (×, ÷) and (+, -)   |  |

- \*1 The number of device points available for a piece of data differs depending on the data type.
- \*2 The total number of sampling data of data logging, event logging, and report data.
- \*3 The total number of units of sampled data per setting is as follows only when the creation trigger and current value data are not synchronized in the report setting.  
Total number of units of data (per setting): 65535, device points (per setting): 65535  
However, note that the number of device points per setting of data excluding the current value data is up to 4096.
- \*4 In high-speed sampling, target data is sampled by synchronizing with a sequence scan from a control CPU module by using the sequence scan synchronization sampling function of a control CPU module.  
When multiple intelligent function modules use the sequence scan synchronization sampling function, note the total number of points for target data. If it exceeds the number of points that can be sampled, an error may occur in registration processing of an intelligent function module registered later.
- \*5 If the number of device points for high speed sampling is increased, an error may occur when updating the settings. If an error occurred, take the following corrective action.
  - Check the settings of other intelligent function modules controlled by the control CPU module, and adjust it so that the total number of device points for the sequence scan synchronization sampling function does not exceed the number of points that can be sampled.
  - Power OFF to ON, or reset the control CPU.
  - Return the number of device points to the original settings.
- \*6 The data type when reading data from the device memory in the CPU module.
- \*7 The number of characters is determined by the specified size.  
For Unicode text file and binary file format, the maximum number of characters is 4096 characters because one character contains two bytes.
- \*8 The format when data is output to Unicode text file or CSV file with data logging or event logging.  
Binary files are output in the binary format.  
Reports are output in Excel cell format.
- \*9 A function to perform data scaling and offset calculations.

### ■ Target sampling data

| Type          | Data type   |
|---------------|---|
| Data logging  | Logging target data, trigger condition data, period condition data, file switching condition data, saved file name data, saved folder name data, e-mail transmission data |
| Event logging | Monitoring data, period condition data, file switching condition data, saved file name data, saved folder name data, e-mail transmission data                             |
| Report        | Current value data, creation trigger condition data, period condition data, saved file name data, saved folder name data, e-mail transmission data                        |

#### Point

The data logging, event logging, and report functions are best effort functions.

Since module processing time changes according to the settings and status of other devices, it may not operate with the set data sampling interval.

Run the system by fully verifying the processing time of each function when constructing it.



For processing time, refer to the following manual.

 MELSEC iQ-R High Speed Data Logger Module User's Manual(Application)

## Data logging performance specifications

| Item                  |   | Specifications   |   |
|-----------------------|---|--|---|
| Data logging          | Number of settings                                | Up to 64 <sup>*1</sup>   |   |
|                       | Logging type                                      | <ul style="list-style-type: none"> <li>• Continuous logging</li> <li>• Trigger logging (output only one line after triggering)</li> <li>• Trigger logging (output the lines before and after triggering)</li> </ul>  |   |
|                       | File format <sup>*2</sup>                         | <ul style="list-style-type: none"> <li>• Unicode text file (extension: .TXT)</li> <li>• CSV file (extension: .CSV)</li> <li>• Binary file (extension: .BIN)<sup>*3</sup></li> </ul>  |   |
|                       | Period  | Specify the applicable period or exclusion period. <ul style="list-style-type: none"> <li>• Data condition: Bit ON/OFF, compare data to constant value, compare data to data</li> <li>• Date range: Specify the start and end in month and day</li> <li>• Time range: Specify the start and end in hour, minute, and second</li> <li>• Day of the week/Week of the month conditions: Specify the day of the week and week</li> </ul> |   |
|                       | Trigger logging                                   | Trigger condition (Single condition)   | <ul style="list-style-type: none"> <li>• Data conditions (comparison): Bit ON/OFF, compare data to constant value, compare data to data</li> <li>• Data conditions (value change)</li> <li>• Fixed cycle: 1 to 86400 seconds</li> <li>• Time interval specification: Specify hour/minute/second</li> <li>• Time specification: Specify month, day, hour, minute, second</li> <li>• At module startup</li> </ul> |
|                       |   | Trigger condition (Compound condition - OR combine)  | <ul style="list-style-type: none"> <li>• Data conditions (comparison): Bit ON/OFF, compare data to constant value, compare data to data</li> <li>• Data conditions (value change)</li> <li>• Fixed cycle: 1 to 86400 seconds</li> <li>• Time interval specification: Specify hour/minute/second</li> <li>• Time specification: Specify month, day, hour, minute, second</li> <li>• At module startup</li> </ul> |
|                       |   | Trigger condition (Compound condition - AND combine)   | <ul style="list-style-type: none"> <li>• Data conditions (comparison): Bit ON/OFF, compare data to constant value, compare data to data</li> </ul>  |
|                       |   | Trigger condition (Compound condition - Number of times)   | Specify the start condition, terminal condition, and count condition. (Up to 3 conditions) <ul style="list-style-type: none"> <li>• Data conditions (comparison): Bit ON/OFF, compare data to constant value, compare data to data</li> <li>• Data conditions (value change)</li> </ul>   |
|                       |   | Trigger condition (Compound condition - Order)   | Specify the start condition and order (1st condition, 2nd condition, or 3rd condition). (Up to 4 conditions) <ul style="list-style-type: none"> <li>• Data conditions (comparison): Bit ON/OFF, compare data to constant value, compare data to data</li> <li>• Data conditions (value change)</li> </ul>   |
|                       |   | Number of logging lines <sup>*4</sup>  | <ul style="list-style-type: none"> <li>• Before trigger occurs: 0 to 65534 lines</li> <li>• After trigger occurs: 1 to 65535 lines</li> </ul> The sum of lines of before and after trigger occurrence is up to 65535 lines.   |
| File switching timing | Number of lines (number of records) specification | 100 to 100000 lines  |   |
|                       | File size specification                           | 10 to 16384 KB   |   |
|                       | Condition specification                           | <ul style="list-style-type: none"> <li>• Data conditions (comparison): Bit ON/OFF, compare data to constant value, compare data to data</li> <li>• Data conditions (value change)</li> <li>• Fixed cycle: 1 to 86400 seconds</li> <li>• Time interval specification: Specify hour/minute/second</li> <li>• Time specification: Specify month, day, hour, minute, second</li> <li>• At module startup</li> </ul>                      |   |
|                       | Trigger logging unit                              | At the time of trigger logging file output completion  |   |

| Item              |                                     | Specifications   |
|-------------------|-------------------------------------|--|
| Data logging      | Number of saved files <sup>*5</sup> | 1 to 65535   |
|                   | Saved file name                     | <ul style="list-style-type: none"> <li>■ Simple setting <ul style="list-style-type: none"> <li>• Add the name</li> <li>• Add the date (4-digit year, month, day)</li> <li>• Add the time (hour, minute, second)</li> <li>• Add the sequential number</li> </ul> </li> <li>■ Detailed setting <ul style="list-style-type: none"> <li>• 4-digit year/2-digit year, month, day, day of the week, hour, minute, second</li> <li>• Device value (two types)</li> <li>• Sequential number</li> </ul> </li> </ul> |
|                   | Folder switching timing             | Condition specification  |
| Saved folder name |                                     | <ul style="list-style-type: none"> <li>■ Simple setting <ul style="list-style-type: none"> <li>• Add the name</li> <li>• Add the date (4-digit year, month, day)</li> <li>• Add the time (hour, minute, second)</li> <li>• Add the sequential number</li> </ul> </li> <li>■ Detailed setting <ul style="list-style-type: none"> <li>• 4-digit year/2-digit year, month, day, day of the week, hour, minute, second</li> <li>• Device value (two types)</li> <li>• Sequential number</li> </ul> </li> </ul> |

- \*1 Up to 64 settings can be configured by combining data logging, event logging, and report function.  
Of these, up to 32 settings can be configured for data logging, event logging, and report function when high speed sampling is specified.
- \*2 For the output file format, refer to the following manual.  
 MELSEC iQ-R High Speed Data Logger Module User's Manual(Application)
- \*3 By using the report function, data can be output again in Excel file format.
- \*4 The number of logging lines setting is affected by the amount of memory (trigger buffer) where sampled data is temporarily saved.  
Since the amount of trigger buffer has an upper limit, there may be situations where the listed number of logging lines cannot be set.  
Confirm the trigger buffer usage amount as given below. Do not exceed the upper limit.  
 MELSEC iQ-R High Speed Data Logger Module User's Manual(Application)
- \*5 When a subfolder is not created in the save folder, the number of saved files is in the range of 1 to 256.

### ■ Restrictions on data logging

The restrictions on performance specifications of data logging are as follows.

| Item  | High speed sampling                                  | General sampling                                     |
|---|--|--|
| Total trigger buffer size   | Up to 20 MB in total using 32 settings <sup>*1</sup> | Up to 20 MB in total using 64 settings <sup>*1</sup> |
| Total number of period condition, trigger condition, file switching condition, and folder switching condition | Up to combination of 5 conditions                    | Up to combination of 10 conditions                   |
| Period condition  | Up to 4 conditions                                   | Up to 8 conditions                                   |
| Trigger condition   | Up to 4 conditions                                   | Up to 8 conditions                                   |
| File switching condition  | Up to 4 conditions                                   | Up to 8 conditions                                   |
| Folder switching condition  | Up to 4 conditions                                   | Up to 8 conditions                                   |

- \*1 Size of the combined high speed sampling and general sampling.  
When 20 MB is used for high speed sampling, trigger logging of general sampling cannot be added.

## Event logging performance specifications

| Item                    |  | Specifications   |   |
|-------------------------|--|--|---|
| Event logging           | Number of settings   | Up to 64 <sup>*1</sup>   |   |
|                         | Number of events   | Up to 256 per event logging setting  |   |
|                         | File format <sup>*2</sup>  | <ul style="list-style-type: none"> <li>Unicode text file (extension: .TXT)</li> <li>CSV file (extension: .CSV)</li> <li>Binary file (extension: .BIN)</li> </ul>   |   |
|                         | Event condition  | Event condition (Single condition)   | <ul style="list-style-type: none"> <li>Data conditions (comparison): Bit ON/OFF, compare data to constant value, compare data to data</li> <li>Data conditions (value change)</li> </ul>  |
|                         |  | Event condition (Compound condition - Comparison - AND combine)  | <ul style="list-style-type: none"> <li>Data conditions (comparison): Bit ON/OFF, compare data to constant value, compare data to data</li> </ul>  |
|                         |  | Event condition (Compound condition - Comparison - OR combine)   | <ul style="list-style-type: none"> <li>Data conditions (comparison): Bit ON/OFF, compare data to constant value, compare data to data</li> </ul>  |
|                         |  | Event condition (Compound condition - Number of times)   | Specify the start condition, terminal condition, and count condition. (Up to 3 conditions) <ul style="list-style-type: none"> <li>Data conditions (comparison): Bit ON/OFF, compare data to constant value, compare data to data</li> <li>Data conditions (value change)</li> </ul>   |
|                         |  | Event condition (Compound condition - Order)   | Specify the start condition and order (1st condition, 2nd condition, or 3rd condition). (Up to 4 conditions) <ul style="list-style-type: none"> <li>Data conditions (comparison): Bit ON/OFF, compare data to constant value, compare data to data</li> <li>Data conditions (value change)</li> </ul>   |
|                         | Period   | Specify the applicable period or exclusion period. <ul style="list-style-type: none"> <li>Data condition: Bit ON/OFF, compare data to constant value, compare data to data</li> <li>Date range: Specify the start and end in month and day</li> <li>Time range: Specify the start and end in hour, minute, and second</li> <li>Day of the week/Week of the month conditions: Specify the day of the week and week</li> </ul> |   |
|                         | File switching timing  | Number of lines (number of records) specification  | 100 to 100000 lines   |
|                         |  | File size specification  | 10 to 16384 KB  |
|                         |  | Condition specification  | <ul style="list-style-type: none"> <li>Data conditions (comparison): Bit ON/OFF, compare data to constant value, compare data to data</li> <li>Data conditions (value change)</li> <li>Fixed cycle: 1 to 86400 seconds</li> <li>Time interval specification: Specify hour/minute/second</li> <li>Time specification: Specify month, day, hour, minute, second</li> <li>At module startup</li> </ul> |
|                         | Number of saved files <sup>*3</sup>  | 1 to 65535   |   |
| Saved file name         | <ul style="list-style-type: none"> <li>■Simple setting               <ul style="list-style-type: none"> <li>Add the name</li> <li>Add the date (4-digit year, month, day)</li> <li>Add the time (hour, minute, second)</li> <li>Add the sequential number</li> </ul> </li> <li>■Detailed setting               <ul style="list-style-type: none"> <li>4-digit year/2-digit year, month, day, day of the week, hour, minute, second</li> <li>Device value (two types)</li> <li>Sequential number</li> </ul> </li> </ul> |  |   |
| Folder switching timing | Condition specification <ul style="list-style-type: none"> <li>Data conditions (comparison): Bit ON/OFF, compare data to constant value, compare data to data</li> <li>Data conditions (value change)</li> <li>Fixed cycle: 1 to 86400 seconds</li> <li>Time interval specification: Specify hour/minute/second</li> <li>Time specification: Specify month, day, hour, minute, second</li> <li>At module startup</li> </ul>  |  |   |

| Item          |                   | Specifications   |
|---------------|-------------------|--|
| Event logging | Saved folder name | <ul style="list-style-type: none"> <li>■Simple setting <ul style="list-style-type: none"> <li>• Add the name</li> <li>• Add the date (4-digit year, month, day)</li> <li>• Add the time (hour, minute, second)</li> <li>• Add the sequential number</li> </ul> </li> <li>■Detailed setting <ul style="list-style-type: none"> <li>• 4-digit year/2-digit year, month, day, day of the week, hour, minute, second</li> <li>• Device value (two types)</li> <li>• Sequential number</li> </ul> </li> </ul> |

- \*1 Up to 64 settings can be configured by combining data logging, event logging, and report function.  
Of these, up to 32 settings can be configured for data logging, event logging, and report function when high speed sampling is specified.
- \*2 For the output file format, refer to the following manual.  
 MELSEC iQ-R High Speed Data Logger Module User's Manual(Application)
- \*3 When a subfolder is not created in the save folder, the number of saved files is in the range of 1 to 256.

### ■Restrictions on event logging

The restrictions on performance specifications of event logging are as follows.

| Item  | High speed sampling               | General sampling                   |
|---|-----------------------------------|------------------------------------|
| Total number of event condition, period condition, file switching condition, and folder switching condition | Up to combination of 5 conditions | Up to combination of 10 conditions |
| Event condition   | Up to 4 conditions                |                                    |
| Period condition  | Up to 4 conditions                | Up to 8 conditions                 |
| File switching condition  | Up to 4 conditions                | Up to 8 conditions                 |
| Folder switching condition  | Up to 4 conditions                | Up to 8 conditions                 |

## Report function performance specifications

| Item                    |                                | Specifications   |   |
|-------------------------|--------------------------------|--|---|
| Report                  | Number of settings             | Up to 64 <sup>*1</sup>   |   |
|                         | File format                    | Excel file (extension: .xls)   |   |
|                         | Output data type               | <ul style="list-style-type: none"> <li>Data inside data logging file<sup>*2</sup></li> <li>Current value data</li> <li>Creation time</li> </ul>  |   |
|                         | Number of units of output data | 64 layouts per report setting, 65535 cells in total  |   |
|                         | Creation trigger               | Trigger condition (Single condition)   | <ul style="list-style-type: none"> <li>Data conditions (comparison): Bit ON/OFF, compare data to constant value, compare data to data</li> <li>Data conditions (value change)</li> <li>Fixed cycle: 1 to 86400 seconds</li> <li>Time interval specification: Specify hour/minute/second</li> <li>Time specification: Specify month, day, hour, minute, second</li> <li>At module startup</li> <li>At the data logging file switching</li> </ul> |
|                         |                                | Trigger condition (Compound condition - OR combine)  | <ul style="list-style-type: none"> <li>Data conditions (comparison): Bit ON/OFF, compare data to constant value, compare data to data</li> <li>Data conditions (value change)</li> <li>Fixed cycle: 1 to 86400 seconds</li> <li>Time interval specification: Specify hour/minute/second</li> <li>Time specification: Specify month, day, hour, minute, second</li> <li>At module startup</li> <li>At the data logging file switching</li> </ul> |
|                         |                                | Trigger condition (Compound condition - AND combine)   | <ul style="list-style-type: none"> <li>Data conditions (comparison): Bit ON/OFF, compare data to constant value, compare data to data</li> </ul>  |
|                         |                                | Trigger condition (Compound condition - Number of times)   | Specify the start condition, terminal condition, and count condition. (Up to 3 conditions) <ul style="list-style-type: none"> <li>Data conditions (comparison): Bit ON/OFF, compare data to constant value, compare data to data</li> <li>Data conditions (value change)</li> </ul>   |
|                         |                                | Trigger condition (Compound condition - Order)   | Specify the start condition and order (1st condition, 2nd condition, or 3rd condition). (Up to 4 conditions) <ul style="list-style-type: none"> <li>Data conditions (comparison): Bit ON/OFF, compare data to constant value, compare data to data</li> <li>Data conditions (value change)</li> </ul>   |
|                         | Period                         | Specify the applicable period or exclusion period. <ul style="list-style-type: none"> <li>Data condition: Bit ON/OFF, compare data to constant value, compare data to data</li> <li>Date range: Specify the start and end in month and day</li> <li>Time range: Specify the start and end in hour, minute, and second</li> <li>Day of the week/Week of the month conditions: Specify the day of the week and week</li> </ul>   |   |
|                         | Layout file size               | Maximum 10 MB  |   |
|                         | Number of saved files          | 1 to 65535   |   |
|                         | Saved file name                | <ul style="list-style-type: none"> <li>■Simple setting               <ul style="list-style-type: none"> <li>Add the name</li> <li>Add the date (4-digit year, month, day)</li> <li>Add the time (hour, minute, second)</li> <li>Add the sequential number</li> </ul> </li> <li>■Detailed setting               <ul style="list-style-type: none"> <li>4-digit year/2-digit year, month, day, day of the week, hour, minute, second</li> <li>Device value (two types)</li> <li>Sequential number</li> </ul> </li> </ul> |   |
| Folder switching timing | Condition specification        | <ul style="list-style-type: none"> <li>Data conditions (comparison): Bit ON/OFF, compare data to constant value, compare data to data</li> <li>Data conditions (value change)</li> <li>Fixed cycle: 1 to 86400 seconds</li> <li>Time interval specification: Specify hour/minute/second</li> <li>Time specification: Specify month, day, hour, minute, second</li> <li>At module startup</li> </ul>  |   |



| Item   |                   | Specifications   |
|--------|-------------------|--|
| Report | Saved folder name | <ul style="list-style-type: none"> <li>■ Simple setting                             <ul style="list-style-type: none"> <li>• Add the name</li> <li>• Add the date (4-digit year, month, day)</li> <li>• Add the time (hour, minute, second)</li> <li>• Add the sequential number</li> </ul> </li> <li>■ Detailed setting                             <ul style="list-style-type: none"> <li>• 4-digit year/2-digit year, month, day, day of the week, hour, minute, second</li> <li>• Device value (two types)</li> <li>• Sequential number</li> </ul> </li> </ul> |

\*1 Up to 64 settings can be configured by combining data logging, event logging, and report function.  
 Of these, up to 32 settings can be configured for data logging, event logging, and report function when high speed sampling is specified.  
 \*2 Only binary format data logging can be output in a report.

### ■ Restrictions on report function

The restrictions on performance specifications of report are as follows.

| Item   | High speed sampling                    | General sampling                       |
|--|--|--|
| Total of layout file sizes   | Up to 10 MB in total using 32 settings | Up to 10 MB in total using 64 settings |
| Total number of period condition, creation trigger condition, and folder switching condition | Up to combination of 5 conditions      | Up to combination of 10 conditions     |
| Period condition   | Up to 4 conditions                     | Up to 8 conditions                     |
| Creation trigger condition   | Up to 4 conditions                     | Up to 8 conditions                     |
| Folder switching condition   | Up to 4 conditions                     | Up to 8 conditions                     |

### Other functions performance specifications

| Item                                |   | Specifications  |  |
|-------------------------------------|---|---|--|
| E-mail                              | Application                                 | <ul style="list-style-type: none"> <li>• Notification when event occurs</li> <li>• Transmit saved file</li> </ul>   |  |
|                                     | Subject                                     | <ul style="list-style-type: none"> <li>• Event notification e-mail: User specified</li> <li>• Saved file transmission e-mail: Automatically created/user specified</li> </ul>                                     |  |
|                                     | Body  | <ul style="list-style-type: none"> <li>• Event notification e-mail: User specified</li> <li>• Saved file transmission e-mail: Automatically created/user specified</li> </ul>                                     |  |
|                                     | Attachment                                  | <ul style="list-style-type: none"> <li>• Event notification e-mail: None</li> <li>• Saved file transmission e-mail: Saved file (Unicode text file, binary file, CSV file, or Excel file), up to 512 KB</li> </ul> |  |
|                                     | Attachment format                           | MIME format   |  |
|                                     | MIME version                                | 1.0   |  |
|                                     | Communications with mail server             | Port number   | 25, 587, other (1 to 65535)  |
|                                     |   | Authentication method   | <ul style="list-style-type: none"> <li>• No authentication</li> <li>• SMTP-AUTH (PLAIN, LOGIN, CRAM-MD5)</li> <li>• POP before SMTP</li> </ul> |
|                                     | Target address                              | Up to 16 groups   |  |
|                                     | Operability verified e-mail client software | Microsoft Outlook 2013  |  |
| FTP server <sup>*1</sup>            | Application                                 | <ul style="list-style-type: none"> <li>• Read and delete saved files</li> <li>• Write, read, and delete recipe files</li> </ul>   |  |
|                                     | Operability verified FTP client software    | Windows Internet Explorer 8.0<br>Windows Internet Explorer 9.0<br>Windows Internet Explorer 10.0<br>Windows Internet Explorer 11.0  |  |
|                                     | Session count <sup>*2</sup>                 | 10  |  |
| FTP transfer <sup>*3</sup> (client) | Application                                 | Transfer saved files  |  |
|                                     | Operability verified FTP server software    | Microsoft Internet Information Services   |  |
|                                     | Number of transfer destination settings     | Up to 16 settings <sup>*4</sup>   |  |
| Shared folder transfer              | Application                                 | Transfer saved files  |  |
|                                     | Operability verified operating system       | Windows 10 (Home, Pro, Enterprise, Education)<br>Windows 8.1, Windows 8.1 (Pro, Enterprise)<br>Windows 8, Windows 8 (Pro, Enterprise)<br>Windows 7 (Starter, Home Premium, Professional, Ultimate, Enterprise)    |  |
|                                     | Number of transfer destination settings     | Up to 16 settings <sup>*4</sup>   |  |

| Item   |                           | Specifications  |
|--------|---------------------------|---|
| Recipe | Number of units of data   | Up to 256 data  |
|        | Number of records         | Up to 256 records   |
|        | Data type                 | <ul style="list-style-type: none"> <li>• Bit</li> <li>• Word [Signed]</li> <li>• Double Word [Signed]</li> <li>• Word [Unsigned]/Bit String [16-bit]</li> <li>• Double Word [Unsigned]/Bit String [32-bit]</li> <li>• FLOAT [Single Precision]</li> <li>• FLOAT [Double Precision]</li> <li>• 16bit BCD</li> <li>• 32bit BCD</li> </ul> |
|        | Recipe file <sup>*5</sup> | CSV file (extension: .CSV), maximum 256 files   |
|        | Execution type            | Dedicated instructions (ladder program), configuration tool   |

\*1 A function to access the high speed data logger module (FTP server) from a personal computer's FTP client software.  
For the corresponding FTP command, refer to the following manual.

 MELSEC iQ-R High Speed Data Logger Module User's Manual(Application)

\*2 The upper limit of the number of simultaneous connections to the high speed data logger module from FTP client software.  
FTP client software may use multiple connections per single access session.

\*3 A function to access the personal computer's FTP server software from the high speed data logger module (FTP client).

\*4 The sum of transfer destination settings in the FTP client and shared folder is up to 16 settings.

\*5 For the output file format, refer to the following manual.

 MELSEC iQ-R High Speed Data Logger Module User's Manual(Application)

## 2.2 Access Specifications for a CPU Module

This section shows the access specifications for a CPU module.

### Accessible CPU modules

| Series             |  | Model   | Data sampling method  |
|--------------------|--|---|---|
| RCPU* <sup>1</sup> | Programmable controller CPU              | R00CPU* <sup>2</sup> , R01CPU* <sup>2</sup> , R02CPU* <sup>2</sup> , R04CPU, R04ENCPU, R08CPU, R08ENCPU, R16CPU, R16ENCPU, R32CPU, R32ENCPU, R120CPU, and R120ENCPU   | <ul style="list-style-type: none"> <li>• High speed sampling</li> <li>• General sampling</li> </ul> |
|                    | Safety CPU* <sup>3</sup>                 | R08SFPCPU, R16SFPCPU, R32SFPCPU, R120SFPCPU   |   |
|                    | Process CPU (process mode)* <sup>4</sup> | R08PCPU, R16PCPU, R32PCPU, and R120PCPU   | <ul style="list-style-type: none"> <li>• General sampling</li> </ul>                                |
|                    | C Controller module* <sup>5</sup>        | R12CCPU-V   |   |
| QCPU (Q mode)      | Programmable controller CPU              | Q00JCPU, Q00UJCPU, Q00CPU, Q00UCPU, Q01CPU, Q01UCPU, Q02CPU, Q02HCPU, Q02UCPU, Q03UDCPU, Q03UDECPU, Q03UDVCPU, Q04UDHCPU, Q04UDEHCPU, Q04UDVCPU, Q06HCPU, Q06UDHCPU, Q06UDEHCPU, Q06UDVCPU, Q10UDHCPU, Q10UDEHCPU, Q12HCPU, Q13UDHCPU, Q13UDEHCPU, Q13UDVCPU, Q20UDHCPU, Q20UDEHCPU, Q25HCPU, Q26UDHCPU, Q26UDEHCPU, Q26UDVCPU, Q50UDEHCPU, and Q100UDEHCPU |   |
|                    | Process CPU                              | Q02PHCPU, Q06PHCPU, Q12PHCPU, and Q25PHCPU  |   |
|                    | C Controller module* <sup>5</sup>        | Q12DCCPU-V* <sup>6</sup> , Q24DHCCPU-V, Q24DHCCPU-LS, and Q24DHCCPU-VG  |   |
| LCPU               | Programmable controller CPU              | L02CPU, L02CPU-P, L02SCPU, L06CPU, L26CPU, L26CPU-BT, and L26CPU-PBT  |   |

- \*1 When using high speed sampling, use a CPU module supporting the sequence scan synchronization sampling function.  
For a CPU module supporting the sequence scan synchronization sampling function, refer to the manual for the CPU module.
- \*2 Use a high speed data logger module the firmware version of which is '05' or later.
- \*3 Use a high speed data logger module the firmware version of which is '07' or later.
- \*4 Process CPUs (redundant mode) are not supported.
- \*5 It cannot be used as a relay station.
- \*6 Only a module with a serial number of which the first five digits are 12042 or higher can be accessed.

# Accessible routes

The following figure shows accessible routes from a high speed data logger module.

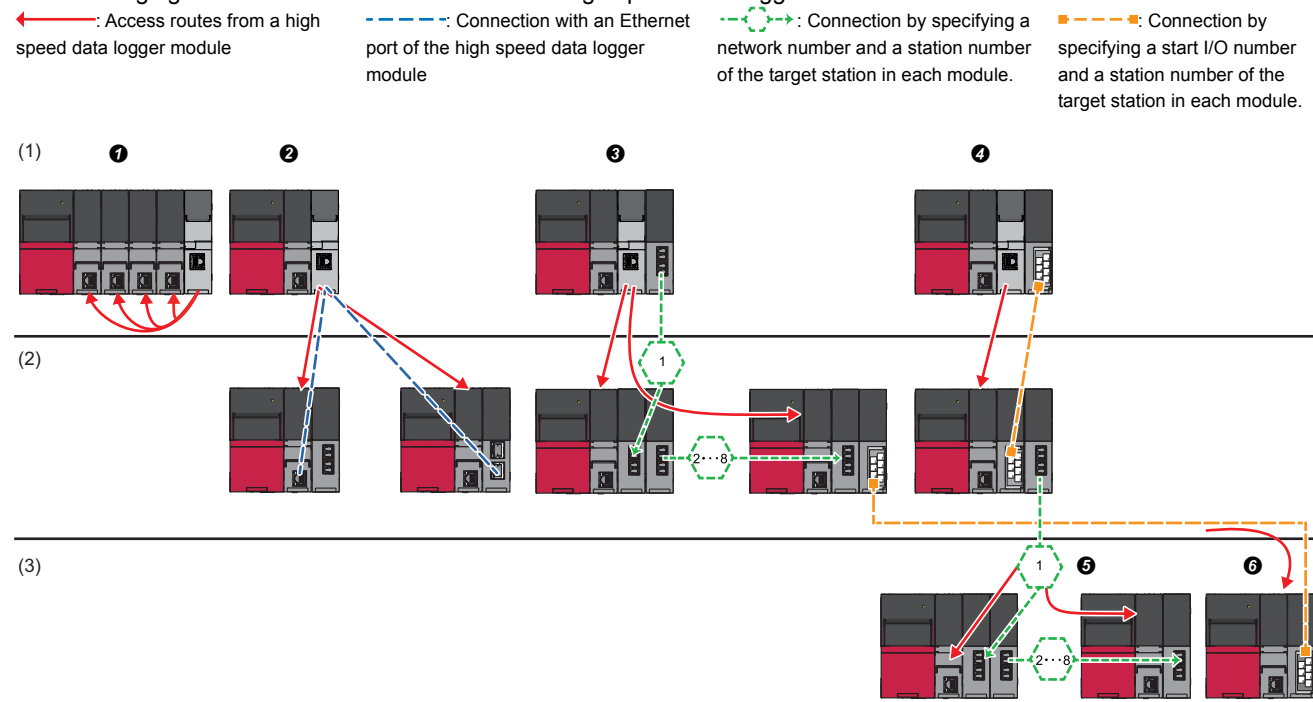

| Accessible routes |  | Reference   |
|-------------------|--|---|
| (1)               | Own station (Control CPU, other CPUs in multiple CPUs) | Page 35 Own station (Control CPU, other CPUs in multiple CPUs)  |
| (2)               | Another station via single network                     | Page 35 Access from the Ethernet port of a high speed data logger module  |
|                   |  | Page 36 Access by specifying the network number and station number of the target station.   |
|                   |  | Page 36 Access by specifying the start I/O number of the module for accessing the target station and station number of the other station  |
| (3)               | Another station via co-existence network               | Page 37 Access by specifying the network number and station number, via another station on CC-Link or C24                                 |
|                   |  | Page 37 Access to another station on CC-Link or C24 from another station on which the network number and the station number are specified |

**Point**

If network load is high, data will not be processed on the device on the access route (including access target CPU) and a timeout error may occur and data sampling may fail. If a timeout error occurs, adjust the network load.

## Own station (Control CPU, other CPUs in multiple CPUs)

The following table shows the accessible route to a CPU module of the high speed data logger module-mounted station.

○: Accessible, —: No combination

| Access route                | Access destination CPU module (series)               |                     |  |                     |                             |
|-----------------------------|--|---------------------|--|---------------------|-----------------------------|
|                             | RCPU   |                     | QCPU (Q mode)                            |                     | LCPU                        |
|                             | Programmable controller CPU/ Process CPU/ Safety CPU | C Controller module | Programmable controller CPU/ Process CPU | C Controller module | Programmable controller CPU |
| Control CPU                 | ○  | —                   | —  | —                   | —                           |
| Other CPUs in multiple CPUs | ○*1<br>(PLC No.1 to No.4)                            | —                   | —  | —                   | —                           |

\*1 RnENCPU is not applicable.

## Another station via single network

### Access from the Ethernet port of a high speed data logger module

The following table shows the accessible route when accessing from an Ethernet port of a high speed data logger module in the status where an access target CPU is connected to a network.

The communication target from an Ethernet port of the high speed data logger module, Ethernet module or CPU module (Ethernet port) can be specified.

○: Accessible, —: No combination

| Access route  | Access destination CPU module (series)               |                         |  |                     |                             |
|---|--|-------------------------|--|---------------------|-----------------------------|
|   | RCPU   |                         | QCPU (Q mode)                            |                     | LCPU                        |
|   | Programmable controller CPU/ Process CPU/ Safety CPU | C Controller module     | Programmable controller CPU/ Process CPU | C Controller module | Programmable controller CPU |
| Ethernet<br>• High speed data logger module Ethernet port → CPU module (Ethernet port)<br>• High speed data logger module Ethernet port → Ethernet module | ○<br>(PLC No.1 to No.4)                              | ○<br>(PLC No.1 to No.4) | ○*1,*2<br>(PLC No.1 to No.4)             | ○*3<br>(Host CPU)   | ○                           |

\*1 An Ethernet module-mounted station or built-in Ethernet CPU can be accessed. Access via relay station is not possible.

\*2 UDP (MELSOFT Connection) needs to be added to the open setting for a built-in Ethernet port of an access target CPU.

\*3 When accessing an Ethernet port of Q12DCCPU-V (Basic mode) directly, MELSOFT connection needs to be permitted in the Q12DCCPU-V (Basic mode) setting.

For details on the setting, refer to the following manual.

 C Controller Module User's Manual (Utility Operation, Programming)

### ■ Access by specifying the network number and station number of the target station

The following table shows the accessible route when an access target CPU module can be specified by a network number and a station number (or CPU number) from the high speed data logger module-mounted station, in the status where the target device is connected to a network.

The access to the CPU module that is mounted on the eighth network is available via a relay station of RCP or QCPU (Q mode).

○: Accessible, —: No combination

| Access route                  |                         | Access destination CPU module (series)               |                         |  |                     |                             |
|-------------------------------|-------------------------|--|-------------------------|--|---------------------|-----------------------------|
|                               |                         | RCP  |                         | QCPU (Q mode)                            |                     | LCP                         |
|                               |                         | Programmable controller CPU/ Process CPU/ Safety CPU | C Controller module     | Programmable controller CPU/ Process CPU | C Controller module | Programmable controller CPU |
| CC-Link IE Controller Network |                         | ○<br>(PLC No.1 to No.4)                              | ○<br>(PLC No.1 to No.4) | ○<br>(PLC No.1 to No.4)                  | ○<br>(Host CPU)     | —                           |
| CC-Link IE Field Network      |                         |  |                         |  |                     | ○                           |
| MELSECNET/H                   |                         |  |                         |  |                     | —                           |
| Ethernet*1                    | Via own Ethernet module |  |                         |  | —                   | ○                           |

\*1 Only Ethernet modules can be accessed from the own station.

### ■ Access by specifying the start I/O number of the module for accessing the target station and station number of the target station

The following table shows the accessible route when connecting an access target CPU module and the side on which high speed data logger module is mounted directly.

○: Accessible, ×: Not accessible

| Access route |  | Access destination CPU module (series)               |                         |  |                     |                             |
|--------------|--|--|-------------------------|--|---------------------|-----------------------------|
|              |  | RCP  |                         | QCPU (Q mode)                            |                     | LCP                         |
|              |  | Programmable controller CPU/ Process CPU/ Safety CPU | C Controller module     | Programmable controller CPU/ Process CPU | C Controller module | Programmable controller CPU |
| CC-Link      |  | ○<br>(PLC No.1 to No.4)                              | ○<br>(PLC No.1 to No.4) | ○<br>(PLC No.1 to No.4)                  | ○<br>(Host CPU)     | ○                           |
| C24          |  |  | ×                       |  | ×                   |                             |

## Another station via co-existence network

### ■ Access by specifying the network number and station number, via another station on CC-Link or C24

The following table shows the accessible route when accessing by specifying a network number and a station number via other stations (the first route) on CC-Link or C24 from the side on which a high speed data logger module is mounted.

○: Accessible, —: No combination

| First access route | Second access route<br>(Co-existence network) | Access destination CPU module (series)               |                         |  |                     |                             |
|--------------------|---|--|-------------------------|--|---------------------|-----------------------------|
|                    |   | RCPU   |                         | QCPU (Q mode)                            |                     | LCPU                        |
|                    |   | Programmable controller CPU/ Process CPU/ Safety CPU | C Controller module     | Programmable controller CPU/ Process CPU | C Controller module | Programmable controller CPU |
| CC-Link<br>C24     | CC-Link IE Controller Network                 | ○<br>(PLC No.1 to No.4)                              | ○<br>(PLC No.1 to No.4) | ○<br>(PLC No.1 to No.4)                  | ○<br>(Host CPU)     | —                           |
|                    | CC-Link IE Field Network                      |  |                         |  |                     | ○                           |
|                    | MELSECNET/H                                   |  |                         |  |                     | —                           |
|                    | Ethernet (via Ethernet module)                |  |                         |  | —                   | ○                           |

### ■ Access to another station on CC-Link or C24 from another station on which the network number and the station number are specified

The following table shows the accessible route when accessing other stations on CC-Link or C24 via a station (the first route) specified by a network number and a station number from the side on which a high speed data logger module is mounted.

○: Accessible, ×: Not accessible

| First access route             | Second access route<br>(Co-existence network) | Access destination CPU module (series)               |                         |  |                     |                             |
|--------------------------------|---|--|-------------------------|--|---------------------|-----------------------------|
|                                |   | RCPU   |                         | QCPU (Q mode)                            |                     | LCPU                        |
|                                |   | Programmable controller CPU/ Process CPU/ Safety CPU | C Controller module     | Programmable controller CPU/ Process CPU | C Controller module | Programmable controller CPU |
| CC-Link IE Controller Network  | CC-Link                                       | ○<br>(PLC No.1 to No.4)                              | ○<br>(PLC No.1 to No.4) | ○<br>(PLC No.1 to No.4)                  | ○<br>(Host CPU)     | ○                           |
| MELSECNET/H                    |   |  |                         |  |                     |                             |
| CC-Link IE Field Network       |   |  |                         |  |                     |                             |
| Ethernet (via Ethernet module) |   |  |                         |  |                     |                             |
| CC-Link IE Controller Network  | C24   |  | ×                       |  | ×                   |                             |
| MELSECNET/H                    |   |  |                         |  |                     |                             |
| CC-Link IE Field Network       |   |  |                         |  |                     |                             |
| Ethernet (via Ethernet module) |   |  |                         |  |                     |                             |

# Accessible devices

The following tables lists the accessible devices.

High speed sampling is possible only for the RCPUC that controls the high speed data logger module.

○: Accessible, ×: Not accessible

| Device <sup>*1</sup> (Device name)       |  | Access destination CPU module (series)  |   |                     |   |                     |                              |
|--|--|---|---|---------------------|---|---------------------|------------------------------|
|  |  | RCPUC   |   | C Controller module | QCPU (Q mode)                             |                     | LCPUC                        |
|  |  | Programmable controller CPU/Process CPU <sup>*2</sup> /Safety CPU <sup>*3</sup> |   |                     | Programma ble controller CPU/ Process CPU | C Controller module | Programma ble controller CPU |
| General sampling                         | High speed sampling  |   |   |                     |   |                     |                              |
| Function input (FX)                      |  | ×   | × | ×                   | ×   | ×                   | ×                            |
| Function output (FY)                     |  | ×   | × | ×                   | ×   | ×                   | ×                            |
| Function register (FD)                   |  | ×   | × | ×                   | ×   | ×                   | ×                            |
| Special relay (SM)                       |  | ○   | ○ | ○                   | ○   | ○ <sup>*4</sup>     | ○                            |
| Special register (SD)                    |  | ○   | ○ | ○                   | ○   | ○ <sup>*4</sup>     | ○                            |
| Input relay (X)                          |  | ○   | ○ | ○                   | ○   | ○ <sup>*4</sup>     | ○                            |
| Output relay (Y)                         |  | ○   | ○ | ○                   | ○   | ○ <sup>*4</sup>     | ○                            |
| Internal relay (M)                       |  | ○   | ○ | ○                   | ○   | ○ <sup>*4</sup>     | ○                            |
| Latch relay (L)                          |  | ○   | ○ | ×                   | ○   | ×                   | ○                            |
| Annunciator (F)                          |  | ○   | ○ | ×                   | ○   | ×                   | ○                            |
| Edge relay (V)                           |  | ○   | ○ | ×                   | ○   | ×                   | ○                            |
| Link relay (B)                           |  | ○   | ○ | ○                   | ○   | ○ <sup>*5</sup>     | ○                            |
| Data register (D)                        |  | ○   | ○ | ○                   | ○   | ○ <sup>*4</sup>     | ○                            |
| Link register (W)                        |  | ○   | ○ | ○                   | ○   | ○ <sup>*5</sup>     | ○                            |
| Extended data register (D) <sup>*6</sup> |  | ×   | × | ×                   | ○   | ○ <sup>*4</sup>     | ○                            |
| Extended link register (W) <sup>*6</sup> |  | ×   | × | ×                   | ○   | ○ <sup>*4</sup>     | ○                            |
| Timer                                    | Contact (TS)   | ○   | ○ | ×                   | ○   | ×                   | ○                            |
|  | Coil (TC)  | ○   | ○ | ×                   | ○   | ×                   | ○                            |
|  | Current value (T/TN) <sup>*7</sup>                         | ○   | ○ | ×                   | ○   | ×                   | ○                            |
| Long timer                               | Contact (LTS)  | ○   | ○ | ×                   | ×   | ×                   | ×                            |
|  | Coil (LTC)   | ○   | ○ | ×                   | ×   | ×                   | ×                            |
|  | Current value (LT/LTN) <sup>*7</sup>                       | ○   | ○ | ×                   | ×   | ×                   | ×                            |
| Counter                                  | Contact (CS)   | ○   | ○ | ×                   | ○   | ×                   | ○                            |
|  | Coil (CC)  | ○   | ○ | ×                   | ○   | ×                   | ○                            |
|  | Current value (C/CN) <sup>*7</sup>                         | ○   | ○ | ×                   | ○   | ×                   | ○                            |
| Long counter                             | Contact (LCS)  | ○   | ○ | ×                   | ×   | ×                   | ×                            |
|  | Coil (LCC)   | ○   | ○ | ×                   | ×   | ×                   | ×                            |
|  | Current value (LC/LCN) <sup>*7</sup>                       | ○   | ○ | ×                   | ×   | ×                   | ×                            |
| Retentive timer                          | Contact (STS, SS <sup>*8</sup> )                           | ○   | ○ | ×                   | ○   | ×                   | ○                            |
|  | Coil (STC, SC <sup>*8</sup> )                              | ○   | ○ | ×                   | ○   | ×                   | ○                            |
|  | Current value (ST/STN, ST/SN <sup>*8</sup> ) <sup>*7</sup> | ○   | ○ | ×                   | ○   | ×                   | ○                            |
| Long retentive timer                     | Contact (LSTS)   | ○   | ○ | ×                   | ×   | ×                   | ×                            |
|  | Coil (LSTC)  | ○   | ○ | ×                   | ×   | ×                   | ×                            |
|  | Current value (LST/ LSTN) <sup>*7</sup>                    | ○   | ○ | ×                   | ×   | ×                   | ×                            |
| Link special relay (SB)                  |  | ○   | ○ | ○                   | ○   | ×                   | ○                            |
| Link special register (SW)               |  | ○   | ○ | ○                   | ○   | ×                   | ○                            |
| Step relay (S)                           |  | ×   | × | ×                   | ×   | ×                   | ×                            |
| Direct input (DX)                        |  | ×   | × | ×                   | ×   | ×                   | ×                            |
| Direct output (DY)                       |  | ×   | × | ×                   | ×   | ×                   | ×                            |
| Index register (Z)                       |  | ○   | ○ | ×                   | ○   | ×                   | ○                            |



| Device *1 (Device name)         |   | Access destination CPU module (series)                 |     |                     |   |                     |      |
|---------------------------------|---|--|-----|---------------------|---|---------------------|------|
|                                 |   | RCPU   |     | C Controller module | QCPU (Q mode)                           |                     | LCPU |
|                                 |   | Programmable controller CPU/Process CPU*2/Safety CPU*3 |     |                     | Programmable controller CPU/Process CPU | C Controller module |      |
| General sampling                | High speed sampling   |  |     |                     |   |                     |      |
| Long index register (LZ)        |   | ○  | ○   | ×                   | ×                                       | ×                   | ×    |
| File register                   | (R)   | ○  | ○*9 | ×                   | ○*10                                    | ×                   | ○    |
|                                 | (ZR)  | ○  | ○*9 | ○                   | ○*10                                    | ×                   | ○    |
|                                 | (ERnR)  | ×  | ×   | ×                   | ×                                       | ×                   | ×    |
| Link direct device              | Link input (JnX)  | ○  | ×   | ○                   | ○                                       | ○                   | ○    |
|                                 | Link output (JnY)   | ○  | ×   | ○                   | ○                                       | ○                   | ○    |
|                                 | Link relay (JnB)  | ○  | ×   | ○                   | ○                                       | ○                   | ○    |
|                                 | Link special relay (JnSB)   | ○  | ×   | ○                   | ○                                       | ○                   | ○    |
|                                 | Link register (JnW)   | ○  | ×   | ○                   | ○                                       | ○                   | ○    |
|                                 | Link special register (JnSW)  | ○  | ×   | ○                   | ○                                       | ○                   | ○    |
| Refresh data register (RD)      |   | ○  | ○   | ×                   | ×                                       | ×                   | ×    |
| Module access device            | Module access device/ Intelligent function module device (UnG)            | ○  | ×   | ○                   | ○                                       | ○                   | ○    |
|                                 | Multiple CPU shared device (U3EnG)  | ×  | ×   | ○                   | ○                                       | ○                   | ○    |
| CPU buffer memory access device | CPU buffer memory access device (U3EnG)                                   | ○  | ×   | ×                   | ×                                       | ×                   | ×    |
|                                 | CPU buffer memory access device (fixed cycle communication area) (U3EnHG) | ○*11   | ×   | ×                   | ×                                       | ×                   | ×    |

\*1 The local devices and file registers for individual programs cannot be accessed by specifying the program name.

Do not use local devices and file registers for individual programs since they may not be read/written correctly.

\*2 Process CPU does not support high speed sampling.

\*3 Safety devices cannot be accessed.

\*4 For Q12DCCPU-V (Basic mode), select "Use device function" on a C Controller module.

\*5 For Q12DCCPU-V, only Q12DCCPU-V (Extended mode) can be accessed.

\*6 The extended data register (D) and extended link register (W) can be accessed by the following two methods.

· Directly specify in the device name of extended data register (D) and extended link register (W)

· Access to the file register (ZR) area assigned to the extended data register (D) and extended link register (W)

\*7 Either of the device names can be specified.

\*8 Device names for QCPU (Q mode), LCPU, and MELSEC-Q series C Controller module.

\*9 When accessing out of the range of the file register (ZR) area, the value of -1(FFFFH) is sampled.

\*10 It is not accessible when using Q00JCPU and Q00UJCPU.

\*11 RnENCPU and safety CPUs have no device.

## Bit specification/digit specification of devices

The following table shows the availability of the digit-specified and bit-specified devices.

When using the high speed sampling function and recipe function, bit specified/digit specified devices cannot be used.

Bit specified/digit specified devices cannot be used for the current value data in the reports.

○: Possible, ×: Not possible

| Device (device name)       |  | Bit specification | Digit specification |
|----------------------------|--|-------------------|---------------------|
| Special relay (SM)         |  | ×                 | ○                   |
| Special register (SD)      |  | ○                 | ×                   |
| Input relay (X)            |  | ×                 | ○                   |
| Output relay (Y)           |  | ×                 | ○                   |
| Internal relay (M)         |  | ×                 | ○                   |
| Latch relay (L)            |  | ×                 | ○                   |
| Annunciator (F)            |  | ×                 | ○                   |
| Edge relay (V)             |  | ×                 | ○ <sup>*1</sup>     |
| Link relay (B)             |  | ×                 | ○                   |
| Data register (D)          |  | ○                 | ×                   |
| Link register (W)          |  | ○                 | ×                   |
| Timer                      | Contact (TS)   | ×                 | ×                   |
|                            | Coil (TC)  | ×                 | ×                   |
|                            | Current value (T/TN)   | ×                 | ×                   |
| Long timer                 | Contact (LTS)  | ×                 | ×                   |
|                            | Coil (LTC)   | ×                 | ×                   |
|                            | Current value (LT/LTN)   | ×                 | ×                   |
| Counter                    | Contact (CS)   | ×                 | ×                   |
|                            | Coil (CC)  | ×                 | ×                   |
|                            | Current value (C/CN)   | ×                 | ×                   |
| Long counter               | Contact (LCS)  | ×                 | ×                   |
|                            | Coil (LCC)   | ×                 | ×                   |
|                            | Current value (LC/LCN)   | ×                 | ×                   |
| Retentive timer            | Contact (STS, SS <sup>*2</sup> )                               | ×                 | ×                   |
|                            | Coil (STC, SC <sup>*2</sup> )                                  | ×                 | ×                   |
|                            | Current value (ST/STN, ST/SN <sup>*2</sup> )                   | ×                 | ×                   |
| Long retentive timer       | Contact (LSTS)   | ×                 | ×                   |
|                            | Coil (LSTC)  | ×                 | ×                   |
|                            | Current value (LST/LSTN)                                       | ×                 | ×                   |
| Link special relay (SB)    |  | ×                 | ○                   |
| Link special register (SW) |  | ○                 | ×                   |
| Index register (Z)         |  | ×                 | ×                   |
| File register              | (R)  | ○                 | ×                   |
|                            | (ZR)   | ○                 | ×                   |
| Link direct device         | Link input (Jn\X)  | ×                 | ○                   |
|                            | Link output (Jn\Y)   | ×                 | ○                   |
|                            | Link relay (Jn\B)  | ×                 | ○                   |
|                            | Link special relay (Jn\SB)                                     | ×                 | ○                   |
|                            | Link register (Jn\W)   | ○                 | ×                   |
|                            | Link special register (Jn\SW)                                  | ○                 | ×                   |
| Module access device       | Module access device/Intelligent function module device (Un\G) | ○                 | ×                   |
|                            | Multiple CPU shared device (U3En\G)                            | ○                 | ×                   |

\*1 Specified by QCPU (Q mode) or LCPU only.

\*2 Device names for QCPU (Q mode), LCPU, and MELSEC-Q series C Controller module.

## Device specification with labels/comments

A device can be specified with a label or a comment by importing global labels (including module labels) set with an engineering tool to a project of the configuration tool.

For details on importing labels, refer to the following manual.

📖 MELSEC iQ-R High Speed Data Logger Module User's Manual(Application)

## Access units

The following table shows the number of device points (access units) that can be accessed in a single process when sampling the device values in the CPU module.

When the number of sampling device points are lower than the access units, the device values of the same sequence scan are sampled.

Since device values are sampled over multiple sequence scans when the number of sampling device points exceed the access units, data inconsistency (old data and new data overlap) may occur.

To prevent data inconsistency, set the number of devices sampled at one time to less than the access units, or use high speed sampling.

For the operation when the number of device points sampled by the trigger logging function exceeds the access units and general sampling is specified for the data sampling method, refer to the following:

📖 MELSEC iQ-R High Speed Data Logger Module User's Manual(Application)

| Series        |                                   | High speed sampling                                  | General sampling                                    | Report current value data  | Recipe read | Recipe write |
|---------------|-----------------------------------|--|---|--|-------------|--------------|
| RCPU          | Programmable controller CPU       | Samples all device values in the same sequence scan. | 118 points <sup>*1</sup><br>58 points <sup>*2</sup> | 960 points <sup>*3,*4</sup> (480 points <sup>*5</sup> , 240 points <sup>*6</sup> )<br>480 points (240 points <sup>*5</sup> , 120points <sup>*6</sup> ) | 118 points  | 78 points    |
|               | Safety CPU                        |  |   |  |             |              |
|               | Process CPU                       | Not supported.                                       |   | 949 points <sup>*3,*4</sup><br>480 points  |             |              |
|               | C Controller module <sup>*8</sup> |  |   |  |             |              |
| QCPU (Q mode) | Excluding basic model QCPU        |  | 96 points <sup>*1</sup><br>48 points <sup>*2</sup>  | 960 points <sup>*4</sup><br>480 points   | —           | —            |
|               | Basic model QCPU <sup>*7</sup>    |  | 64 points   | 240 points   |             |              |
|               | C Controller module <sup>*8</sup> |  | 96 points <sup>*1</sup><br>48 points <sup>*2</sup>  | 960 points <sup>*4</sup><br>480 points   |             |              |
| LCPU          | Programmable controller CPU       |  | 96 points <sup>*1</sup><br>48 points <sup>*2</sup>  | 960 points <sup>*4</sup><br>480 points   |             |              |

\*1 When accessing from other than the Ethernet port of a high speed data logger module

\*2 When accessing from the Ethernet port of a high speed data logger module

\*3 When "Own station" is selected in the [Station specification] tab of the access target CPU setting.

\*4 When "CC-Link Module" or "Serial Communication Module" is selected for the module type of the access source system under the [Network route] tab of the access target CPU setting, and "Use the co-existence network route" is unselected.

\*5 When accessing long counter

\*6 When accessing long timer and long retentive timer

\*7 Indicates Q00JCPU, Q00CPU, and Q01CPU

\*8 To prevent data inconsistency, use the MELSEC data link functions such as mdSendEx to write devices of the C Controller.

## 2.3 File Structure

It shows the file and folder structure to be created by the high speed data logger module.

### Folder structure of the SD memory card

The following figure shows the directory structure of the SD memory card inserted in the high speed data logger module. When accessed with the FTP function, below '/' is the SD memory card root directory.

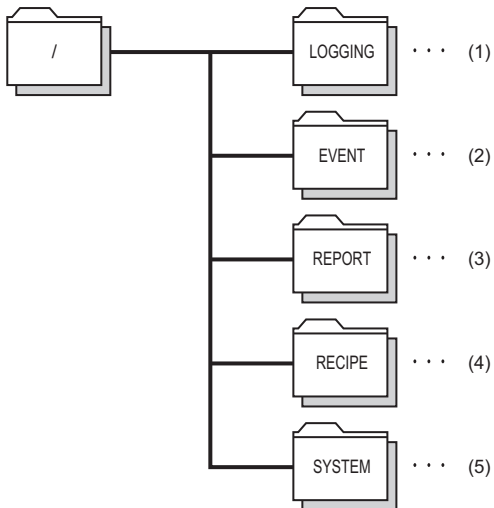

- (1) Data logging file storage directory
- (2) Event logging file storage directory
- (3) Report file storage directory
- (4) Recipe file storage directory
- (5) Directory used by the system

Refer to the following manual for accesses authority of each directory.

 MELSEC iQ-R High Speed Data Logger Module User's Manual(Application)

## Folder structure at the time of file transfer

When using file transfer function, the folder saved on the SD memory card in the high speed data logger module will be saved in the directory of file server.

The following figure shows the directory structure.

### When creating subfolder

Create a setting type folder and subfolder specified by the user on the file server, and transfer logging files at the time of the file switching.

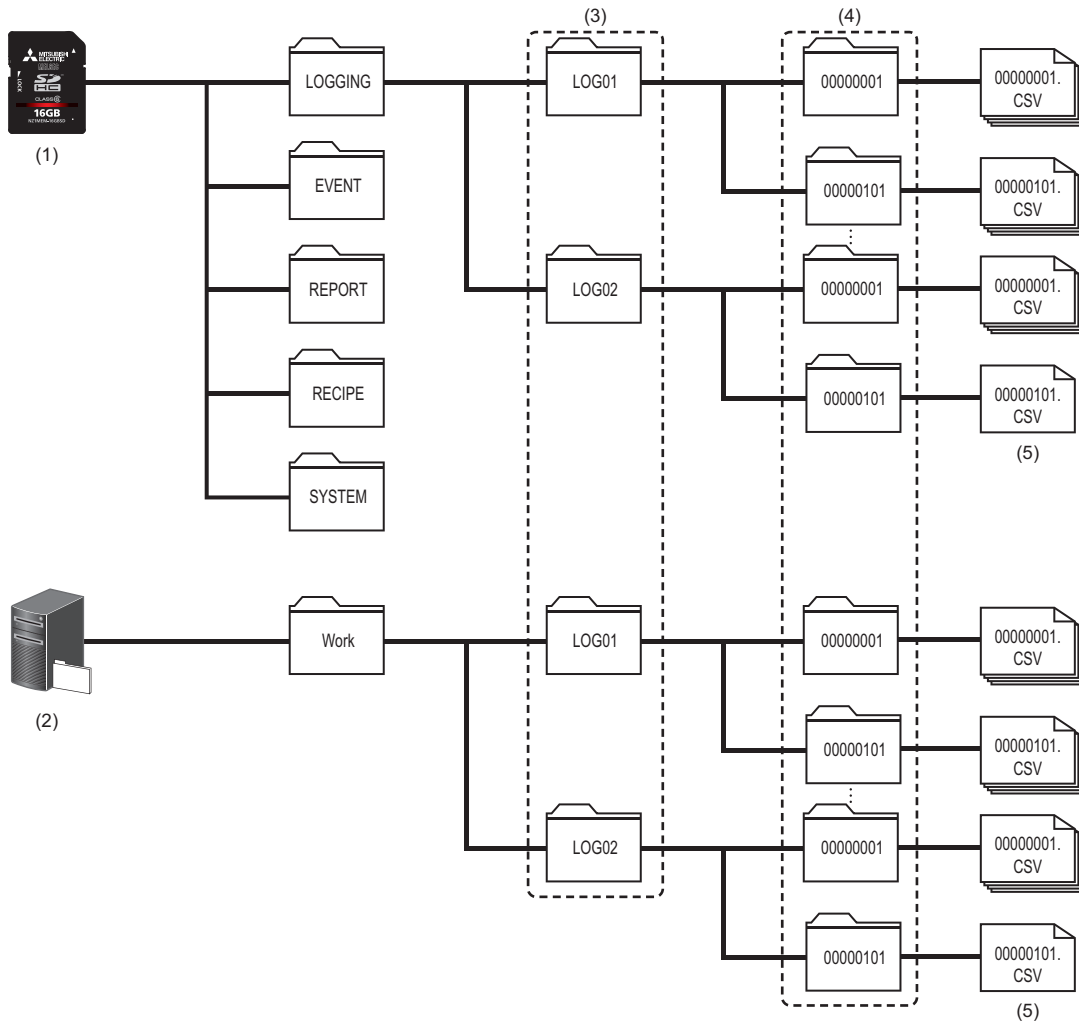

- (1) SD memory card
- (2) File server (FTP server, shared folder)
- (3) Setting type folder
- (4) Subfolder
- (5) Latest saved file

## When not creating subfolder

Create only a setting type folder specified by the user on the file server, and transfer logging files at the time of the file switching.

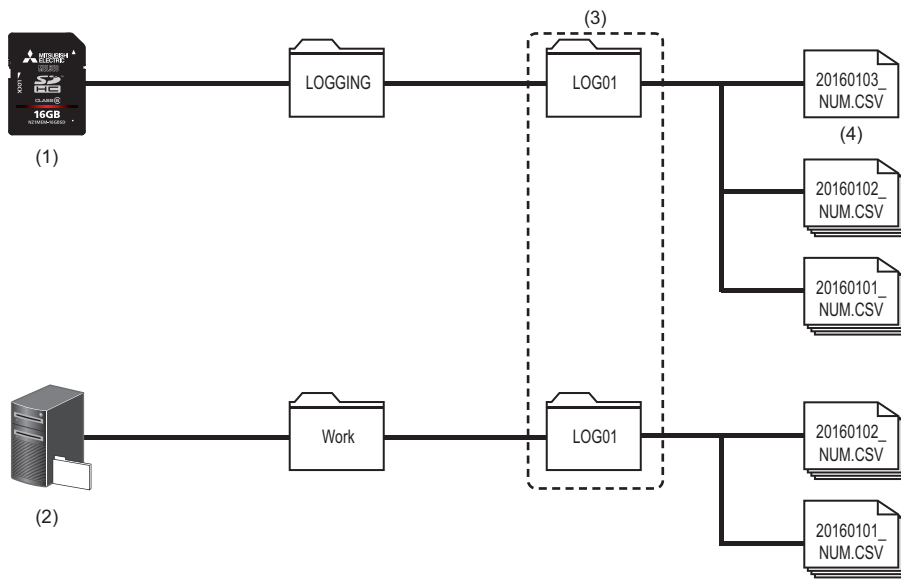

- (1) SD memory card
- (2) File server (FTP server, shared folder)
- (3) Setting type folder
- (4) Accumulating file

## 2.4 Range of Values per Output Format

This section shows the range of values that can be output for each output format.

### Integer type

The ranges of the values that can be represented in each integer type are as follows.

| Output format                              | Lower limit | Upper limit |
|--|-------------|-------------|
| Word [Signed]                              | -32768      | 32767       |
| Double Word [Signed]                       | -2147483648 | 2147483647  |
| Word [Unsigned]/Bit String [16-bit]        | 0           | 65535       |
| Double Word [Unsigned]/Bit String [32-bit] | 0           | 4294967295  |
| 16bit BCD                                  | 0000        | 9999        |
| 32bit BCD                                  | 00000000    | 99999999    |

#### Point

If device values or values after scaling exceed the range, they are rounded within the range.

- If the value exceeds the upper limit value, the upper limit value is output.
- If the value is lower than the lower limit value, the lower limit value is output.

### Float type

The ranges of the values that can be represented in each float type are as follows.

| Output format            | Negative values           |   | Positive values                        |                          |
|--------------------------|---------------------------|---|--|--------------------------|
|                          | Lower limit               | Upper limit                             | Lower limit                            | Upper limit              |
| FLOAT [Single Precision] | -3.4028235E+38            | -1.401298E-45                           | 1.401298E-45                           | 3.4028235E+38            |
| FLOAT [Double Precision] | -1.79769313486231570E+308 | -4.94065645841246544E-324 <sup>*1</sup> | 4.94065645841246544E-324 <sup>*2</sup> | 1.79769313486231570E+308 |

\*1 -1.79769313486231570E-308 with the report function.

\*2 1.79769313486231570E-308 with the report function.

#### Point

If device values or values after scaling exceed the range, the data is output as follows:

- If the value exceeds the upper limit value of positive value, '+Inf' is output.
- If the value is lower than the lower limit value of negative value, '-Inf' is output.
- For values in a range between the upper limit value of negative value and the lower limit value of positive value, '0' is output.

| Output format            | -Inf               | 0                  | +Inf               |
|--------------------------|--------------------|--------------------|--------------------|
| FLOAT [Single Precision] | 0xff800000         | 0x00000000         | 0x7f800000         |
| FLOAT [Double Precision] | 0xffff000000000000 | 0x0000000000000000 | 0x7ff0000000000000 |

### Count/Time

The value ranges that can be represented when the output value other than "value" is specified with trigger logging of data logging are as follows.

| Output value             | Lower limit  | Upper limit |
|--------------------------|--|-------------|
| Value                    | <a href="#">Page 45 Integer type</a><br><a href="#">Page 45 Float type</a> |             |
| Count                    | 0  | 4294967295  |
| Total count              | 0  | 4294967295  |
| Time <sup>*1</sup>       | 0  | 4294967295  |
| Total time <sup>*1</sup> | 0  | 4294967295  |

\*1 A unit specified in the configuration tool is applied (in seconds or milliseconds).

# 3 FUNCTION LIST

This chapter shows the function list of a high speed data logger module and a configuration tool.

For details on the functions, refer to the following manual.

📖 MELSEC iQ-R High Speed Data Logger Module User's Manual(Application)

## 3.1 Function List of a High Speed Data Logger Module

This section shows the function list of a high speed data logger module.

| Function               |                                 | Description  |
|------------------------|---------------------------------|--|
| Data logging function  | —                               | A function to log CPU module device values at the specified data sampling interval.  |
|                        | Data sampling function          | A function to sample the device values from the target CPU module. The sampling interval that can be specified differs depending on the data sampling method.  |
|                        | Continuous logging function     | A function to continuously log CPU module device values at the specified data sampling interval.   |
|                        | Trigger logging function        | A function to only log the specified number of lines worth of CPU module device values before and after a trigger occurs (specified condition is established).   |
|                        | Scaling function                | A function to use linear function transformation for sampled device values.  |
|                        | Save function                   | A function to save data logging target data to the SD memory card in the Unicode text file format, CSV file format, or binary file format.   |
| Event logging function | —                               | A function to monitor device values sampled by a CPU module and to log occurred events.  |
|                        | Data sampling function          | A function to sample the device values from the target CPU module. The sampling interval that can be specified differs depending on the data sampling method.  |
|                        | Scaling function                | A function to use linear function transformation for sampled device values.  |
|                        | E-mail notification function    | A function to notify events to the specified e-mail address by e-mail each time an event occurs.   |
|                        | Save function                   | A function to save event logging target data to the SD memory card in the Unicode text file format, CSV file format, or binary file format.  |
| Report function        | —                               | A function to output data sampled by a high speed data logger module in Excel file format. By using Excel graphs and calculation formulas, easy-to-read reports can be created.  |
|                        | Data sampling function          | A function to sample the device values from the target CPU module. The sampling interval that can be specified differs depending on the data sampling method.  |
|                        | Current value sampling function | A function to sample the data to be output to a report when trigger is generated.  |
|                        | Creation trigger function       | A function to start the report creation at the specified timing.   |
|                        | Scaling function                | A function to use linear function transformation for sampled device values.  |
|                        | Save function                   | A function to save report files to the SD memory card.   |
| Recipe function        |                                 | A function to execute the following operations using recipe files stored in the SD memory card. <ul style="list-style-type: none"> <li>• Reads device values written on the recipe files to devices in the CPU module.</li> <li>• Writes device values in the CPU module to the recipe files.</li> </ul> |
| Security function      | —                               | A function to protect a high speed data logger module against threats such as theft, tampering, faulty operation, and unauthorized execution due to the unauthorized access by the third party.  |
|                        | Access authentication function  | A function to authenticate user name and password to restrict the access to the high speed data logger module.   |
|                        | IP filter function              | A function to identify the IP address of the access source and restrict the access to the high speed data logger module.   |



| Function             |  | Description  |
|----------------------|--|--|
| Other functions      | Time synchronization function  | A function to synchronize the time of the high speed data logger module with a CPU module.   |
|                      | Auto logging function  | A function to automatically start the data logging function, event logging function, and report function when a SD memory card with the auto logging settings written to it in advance is inserted in a running high speed data logger module. |
|                      | File access function   | A function to download data logging files, event logging files, report files and recipe files from the SD memory card inserted in the high speed data logger module to a personal computer or delete them.                                     |
|                      | File transfer function   | A function to automatically transfer saved logging files and report files to the FTP server or shared folder.  |
|                      | E-mail function  | A function to automatically send saved logging files and report file, or notify event occurrences.   |
|                      | Event history function   | A function to record event generated by the high speed data logger module in event history file.   |
|                      | Free space adjustment function   | A function to delete old logging files and report files when the free space of an SD memory card reaches the specified free space.   |
|                      | FTP server function  | A function to access FTP client from personal computer with respect to the file in the SD memory card mounted on the high speed data logger module.  |
|                      | Self-diagnostics function  | A function to perform self-diagnostics test to check the hardware of the high speed data logger module.  |
| Online module change | A function to change modules without stopping the running system. For the procedure, refer to the following manual.<br>□ MELSEC iQ-R Online Module Change Manual |  |

## 3.2 Function List of Configuration Tool

This section shows the function list of the configuration tool.

| Function                       |                                       | Description  |
|--------------------------------|---------------------------------------|--|
| Project management function    | —                                     | A function to create or edit setting file (project file) of the high speed data logger module.   |
|                                | Import function                       | A function to import any setting from project file saved in the personal computer.   |
|                                | Export function                       | A function to output the project which is being edited on the configuration tool as a setting information CSV file. It can also be output to the SD memory card inserted in the personal computer in a module-operable format. |
|                                | Project file conversion function      | A function to convert the project file created using a Q series high speed data logger module to that of the high speed data logger module.  |
| Data logging setting function  |                                       | A function to configure the settings to use the data logging function of the high speed data logger module.  |
| Event logging setting function |                                       | A function to configure the settings to use the event logging function of the high speed data logger module.   |
| Report setting function        | —                                     | A function to configure the settings to use the report function of the high speed data logger module.  |
|                                | Excel layout setting function         | A function to set the layout of a report file to be created using the report function on Excel.  |
| Common setting function        | —                                     | A function to configure the settings to use the security function and other functions of the high speed data logger module.  |
|                                | Network setting function              | A function to set the IP address and network connection related settings of the high speed data logger module.   |
|                                | Time synchronization setting function | A function to configure the settings to use the time synchronization function of the high speed data logger module.  |
|                                | Access target CPU setting function    | A function to set the target CPU module for sampling data of the high speed data logger module.  |
|                                | File transfer setting function        | A function to set the information of the file server that transfers the created file.  |
|                                | E-mail setting function               | A function to set SMTP server and destination addresses for sending created file or notifying event.   |
|                                | Security setting function             | A function to configure the settings to use the access authentication function and IP filter function of the high speed data logger module.  |
|                                | Logging operation setting function    | A function to configure the settings to use the auto logging function of the high speed data logger module. Operation start wait time of the high speed data logger module can be specified.                                   |
|                                | SD memory card setting function       | A function to configure the settings to use the free space adjustment function.  |

| Function                                    |                             | Description  |
|---|-----------------------------|--|
| Online startup function                     |                             | A function to start the configuration tool online from the high speed data logger module by connecting the personal computer to the high speed data logger module. It is not necessary to install the configuration tool on a personal computer. |
| Online function                             | —                           | A function to read and write a parameter, and check the operation by connecting the high speed data logger module from the configuration tool.   |
|   | Module search function      | A function to search for and connect to the high speed data logger modules on the network.   |
|   | Direct connection function  | A function to connect a personal computer to the high speed data logger module on a 1:1 basis using an Ethernet cable. They can be easily connected without concerning the IP address.   |
|   | Module diagnostics function | A function to check the operating status of the high speed data logger module and operate it. The error status of the high speed data logger module can be checked, and access to the SD memory card can be stopped or restarted.                |
|   | File browser function       | A function to access the file in the SD memory card inserted in the high speed data logger module from a personal computer with the exclusive browser.   |
|   | Recipe execution function   | A function to manipulate recipe files saved in the SD memory card mounted on the high speed data logger module.  |
| Recipe file edit function                   |                             | A function to create or edit recipe files used in the recipe function of the high speed data logger module.  |
| Global label/Device comment import function |                             | A function to import global labels and device comments created in the engineering tool to the setting of the high speed data logger module.  |



# Procedure to operate without installing the configuration tool

This section shows the procedure for using the high speed data logger module without installing the configuration tool. For the setting method using the configuration tool, refer to the following manual.

📖 MELSEC iQ-R High Speed Data Logger Module User's Manual(Application)

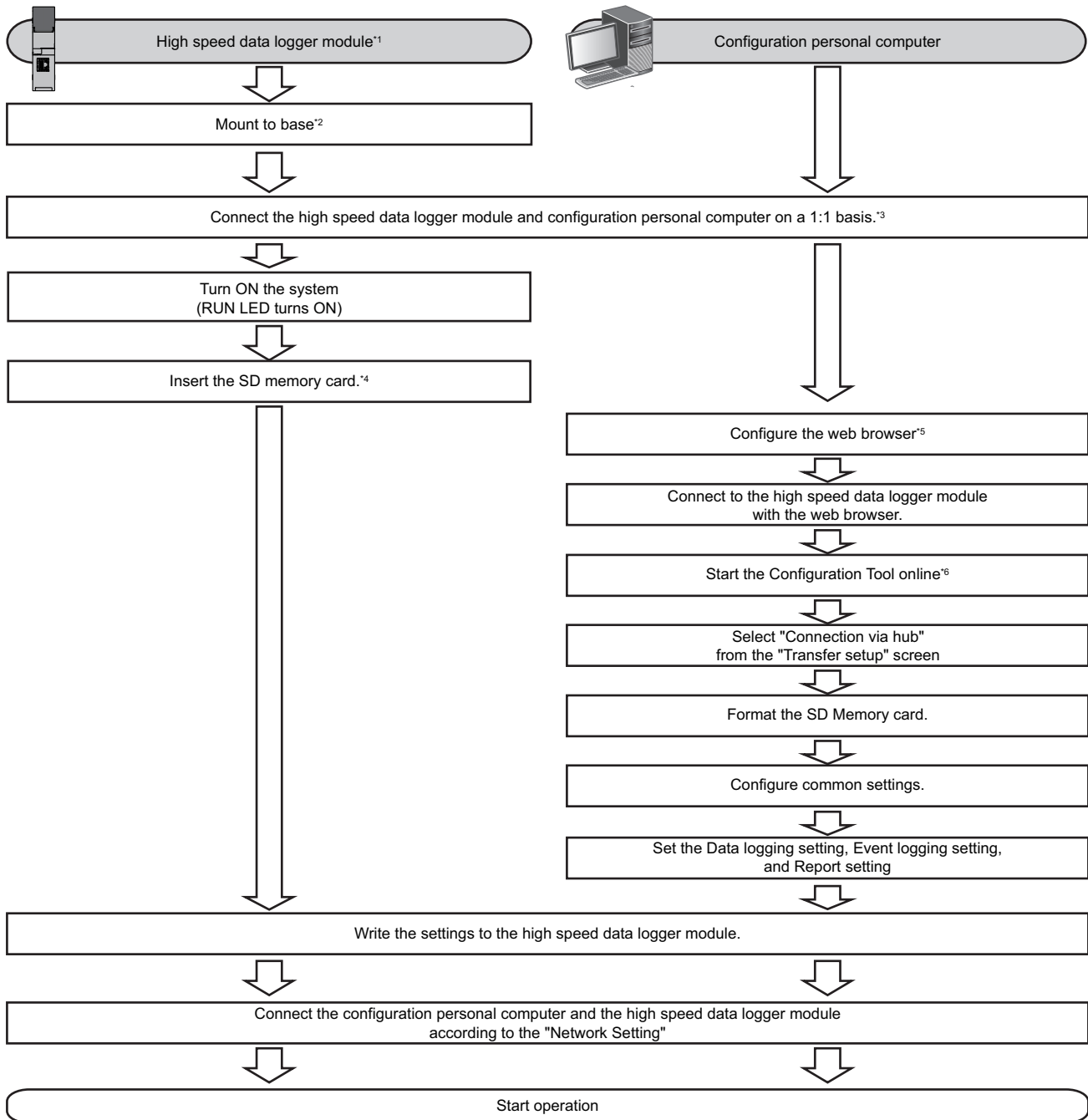

\*1 Perform a self-diagnostics test as necessary. (📖MELSEC iQ-R High Speed Data Logger Module User's Manual(Application))

\*2 Do not use an electric screwdriver to attach and remove module fixing screws.

\*3 📖 Page 68 System configuration for the initial setup, maintenance, and inspection  
📖 Page 51 Network settings for connection

\*4 📖 Page 62 SD Memory Card

\*5 📖 Page 53 Configure the web browser

\*6 📖 Page 53 Online startup

## Network settings for connection

### Operating procedure

1. Set such that the network portion of the configuration personal computer and the configuration tool is the same.

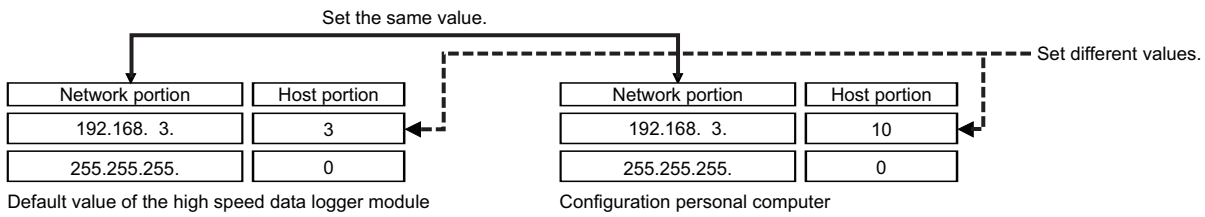

2. Configure the network settings on the "Internet Protocol Version 4 (TCP/IPv4) Properties" screen on the configuration personal computer.

(Example) Windows 7 Ultimate

- 1 Select [Control Panel] ⇒ [Network and Internet] ⇒ [Network and Sharing Center] ⇒ [Change adapter settings].
- 2 Select "Local Area Connection" and click [Properties] on the right click menu.
- 3 On the "Local Area Connection Properties" screen, select "Internet Protocol Version 4 (TCP/IPv4)", then click the [Properties] button.
- 4 The "Internet Protocol Version 4 (TCP/IPv4) Properties" screen is displayed.

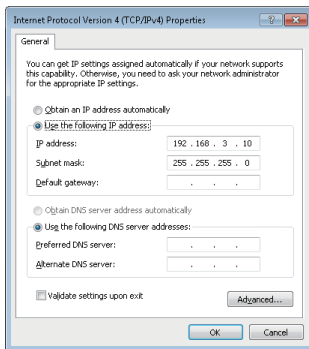

3. Restart the personal computer to enable the network settings.

# Configuration tool

A tool that performs the following operations.

- Edit the settings of the module.
- Write the settings to the module.
- Read the settings from the module.
- Display the operating status of the running module.
- Operate the running module.

For details of the configuration tool, refer to the following manual.

📖 MELSEC iQ-R High Speed Data Logger Module User's Manual(Application)

## Startup method

The following methods show the startup method of the configuration tool.

| Startup method  | Features   | Reference               |
|-----------------|--|-------------------------|
| Offline startup | <ul style="list-style-type: none"><li>• Start the configuration tool installed on the configuration personal computer from Windows Start.</li><li>• Can be started without the high speed data logger module.</li><li>• Can connect to the high speed data logger module without setting the IP address.</li><li>• Can connect to a high speed data logger module even if the configuration personal computer and the high speed data logger module have different subnet masks.</li></ul> | Page 52 Offline startup |
| Online startup  | <ul style="list-style-type: none"><li>• A method to start the configuration tool directly from the high speed data logger module.</li><li>• Not necessary to install the configuration tool on the configuration personal computer.</li></ul>  | Page 53 Online startup  |

## Offline startup

### Operating procedure

1. Select [MELSOFT] ⇒ [Logging Function]<sup>\*2</sup> ⇒ [MELSEC iQ-R High Speed Data Logger Module Configuration Tool] from Windows Start<sup>\*1</sup>.

\*1 Select [All apps] on the Start screen or [Start] ⇒ [All Programs]/[All apps].

\*2 Does not appear in Windows 8 or later.

## Online startup

### ■ Operating procedure prior to online startup

1. Connect the personal computer to the high speed data logger module.  
☞ Page 68 System configuration for the initial setup, maintenance, and inspection
2. Configure the web browser.  
☞ Page 53 Configure the web browser
3. Connect with the web browser.  
☞ Page 56 Connect with the web browser
4. Start the configuration tool.  
☞ Page 56 Start the configuration tool

### ■ Configure the web browser

Configure the following settings with Internet Explorer.

- Local area network (LAN) setting

Unselect the "Automatically detect settings", "Use automatic configuration script", and "Use a proxy server for your LAN" on the "Local Area Network (LAN) Settings" screen.

**Ex.**

Windows 7, Internet Explorer 10.0

Select [Tool] ⇒ [Internet Options] ⇒ [Connections] tab, click the [LAN Settings] button to display the "Local Area Network (LAN) Settings".

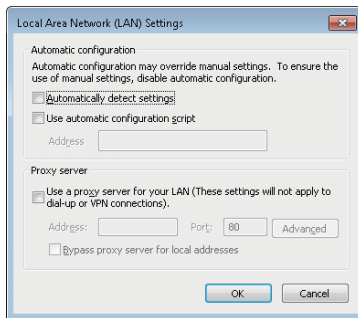

- "Check for newer versions of stored pages" setting

Select the "Every time I visit the webpage" on the "Website Data Settings" screen.

**Ex.**

Windows 7, Internet Explorer 10.0

Select [Tool] ⇒ [Internet Options] ⇒ [General] tab, click the [Settings] button under "Browsing history".

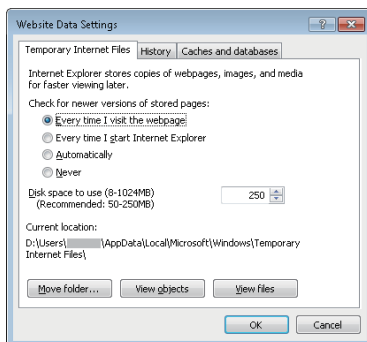

- Delete temporary internet files

Select "Temporary Internet files and website files" on the "Delete Browsing History" screen.

**Ex.**

Internet Explorer 10.0

Select [Tool] ⇒ [Internet Options] ⇒ [General] tab, click the [Delete] button under "Browsing history".

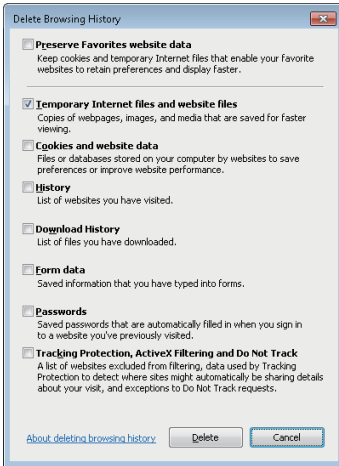

- Security setting

In the [Security] tab on the "Internet Options" screen, set the "Security level for this zone" to "Medium" or lower.

**Ex.**

Internet Explorer 10.0

Select [Tool] ⇒ [Internet Options] ⇒ [Security] tab.

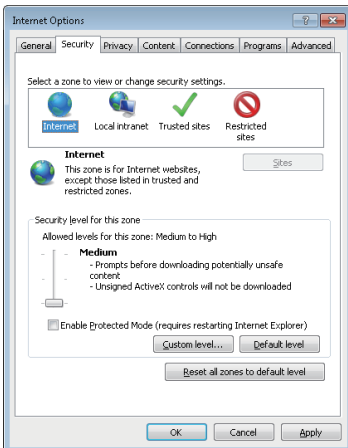



- Disable SmartScreen

For Windows 8, Windows 8.1, and Windows 10, disable SmartScreen according to the following procedures.

Windows 8, Windows 8.1

- 1.** Select [Control Panel] ⇒ [System and Security].
- 2.** Select "Action Center" on the "System and Security" screen.
- 3.** Select "Change Windows SmartScreen settings" on the "Action Center" screen.
- 4.** Select "Don't do anything (turn off Windows SmartScreen)".

Windows 10

- 1.** Select [Control Panel] ⇒ [System and Security].
- 2.** Select "Security and Maintenance" on the "System and Security" screen.
- 3.** Select "Change Windows SmartScreen settings" on the "Security and Maintenance" screen.
- 4.** Select "Don't do anything (turn off Windows SmartScreen)".

## ■Connect with the web browser

Start Internet Explorer, and enter the address of a high speed data logger module ("http://192.168.3.3").

If the IP address is changed, specify the IP address set in the network settings. (MELSEC iQ-R High Speed Data Logger Module User's Manual(Application))



### Point

- If the high speed data logger module cannot be connected normally, issue the PING command from the personal computer to the high speed data logger module to verify the connection.

## ■Start the configuration tool

The following shows the procedure to start the configuration tool.

### Operating procedure

1. Click the "Start the Configuration Tool" on the screen of a web browser.
2. Click the [Run] button on the "Application Run - Security Warning" screen.

The configuration tool is downloaded from the high speed data logger module and started.

## Screen configuration

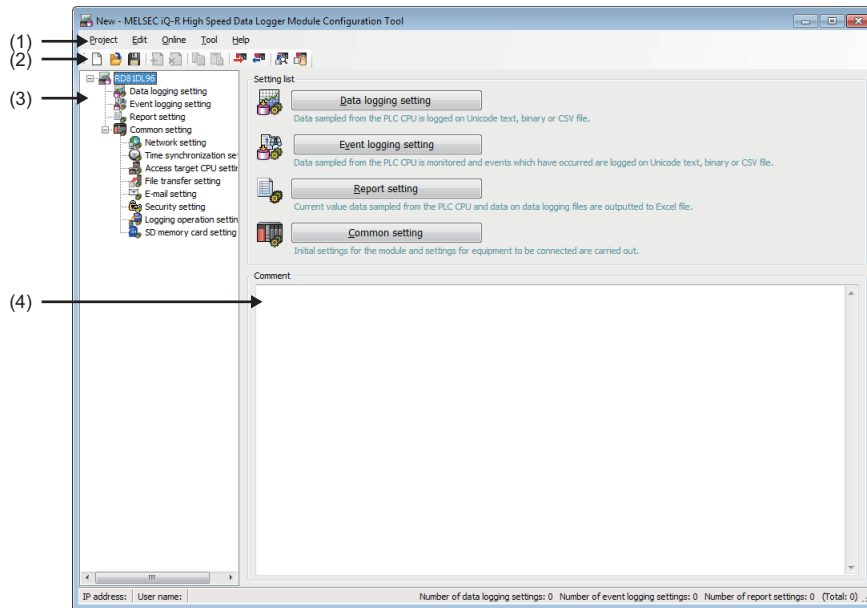

- (1) Menu
- (2) Toolbar
- (3) Edit item tree
- (4) Comment

### ■ Menu configuration











The following table shows the menu configuration of the configuration tool.

| Item    |  |                               | Description  |  |
|---------|--|-------------------------------|--|--|
| Project | New  |                               | Discards the project being edited and creates a new project.   |  |
|         | Open   |                               | Opens a project file saved in the personal computer.   |  |
|         | Save   |                               | Overwrites and saves the project being edited in a file.   |  |
|         | Save as  |                               | Saves the project which is being edited under a new file name.   |  |
|         | Open Q-Series High Speed Data Logger Module (QD81DL96) project |                               | Opens the project file created using the Q series high speed data logger module configuration tool.                                    |  |
|         | Import   | Project file                  | Imports the specified settings from the project files saved in the personal computer.  |  |
|         | Export   | Module operating file         |  | Exports the project which is being edited to the SD memory card inserted in the personal computer in a module-operable format. |
|         |  | Text file                     | Unicode text file  | Exports the settings of the project being edited in the Unicode text file format.  |
|         |  |                               | CSV file   | Exports the settings of the project being edited in the CSV file format.   |
|         | Recent files   |                               | Opens files which were recently used by the configuration tool. (Maximum 5 files)  |  |
| Exit    |  | Exits the configuration tool. |  |  |
| Edit    | Add item   |                               | Adds the item selected in the edit item tree to the setting. The index of the items to be added is the smallest number of the setting. |  |
|         | Delete item  |                               | Deletes the item selected in the edit item tree.   |  |
|         | Replicate item   |                               | Adds an item selected in the edit item tree by copying it. The index of the copied item is the smallest number of the setting.         |  |
|         | Copy settings  |                               | Copies table format settings.  |  |
|         | Paste settings   |                               | Pastes the copied table format settings.   |  |
|         | Move settings up to top  |                               | Moves the selected table format settings upward.   |  |
|         | Device batch replacement                                       |                               | Replaces all the setting devices.  |  |
|         | Import global label  |                               | Imports global labels as data from the project file of an engineering tool.  |  |
|         | Release relation to global label                               |                               | Disables relations between the data and import source global labels.   |  |
|         | Update data related to global label                            |                               | Updates the values of data when the values of import source global labels are changed.   |  |
|         | Import common device comment                                   |                               | Imports common device comments as data from the project file of an engineering tool.   |  |

| Item   |   | Description   |
|--------|---|---|
| Online | Transfer setup                                      | Configures the communications settings when connecting to the high speed data logger module.  |
|        | Read  | Reads the settings from the high speed data logger module.  |
|        | Write   | Writes the settings to the high speed data logger module.   |
|        | Verify  | Verifies the configuration tool setting data with the high speed data logger module.  |
|        | Diagnostics   | Connects to a high speed data logger module, and performs diagnostics of the module .   |
|        | File browser  | Connects to a high speed data logger module, and uploads or downloads files on the inserted SD memory card inserted in the high speed data logger module. |
|        | Recipe execution operation                          | Connects to a high speed data logger module, and reads/writes recipe files on the SD memory card inserted in the high speed data logger module.           |
| Tool   | Start GX LogViewer                                  | Starts GX LogViewer.  |
|        | Display recipe editor                               | Displays the "Recipe Editor" screen.  |
| Help   | About configuration tool                            | Displays configuration tool version information.  |
|        | Connection to MITSUBISHI ELECTRIC FA Global Website | Open the MITSUBISHI ELECTRIC FA Global Website in a Web browser.  |
|        | MELSEC iQ-R High Speed Data Logger Module Help      | Displays the user's manual of the high speed data logger module.  |

## ■Toolbar configuration

The toolbar configuration of the configuration tool is as shown below.

| Icon  | Corresponding menu        |
|---|---------------------------|
|    | [Project] ⇒ [New]         |
|    | [Project] ⇒ [Open]        |
|    | [Project] ⇒ [Save]        |
|  | [Edit] ⇒ [Add item]       |
|  | [Edit] ⇒ [Delete item]    |
|  | [Edit] ⇒ [Copy settings]  |
|  | [Edit] ⇒ [Paste settings] |
|  | [Online] ⇒ [Write]        |
|  | [Online] ⇒ [Read]         |
|  | [Online] ⇒ [Diagnostics]  |
|  | [Online] ⇒ [File browser] |

## ■Comment

Write comments (up to 2048 characters) related to the project.

The first line (up to 160 characters) up to the comment linefeed is displayed in "Comment" on the "Find High Speed Data Logger Module" screen.

## Operations using the edit item tree

The edit item tree shows the overall project settings in a tree display.

The operations using the edit item tree is as shown below.

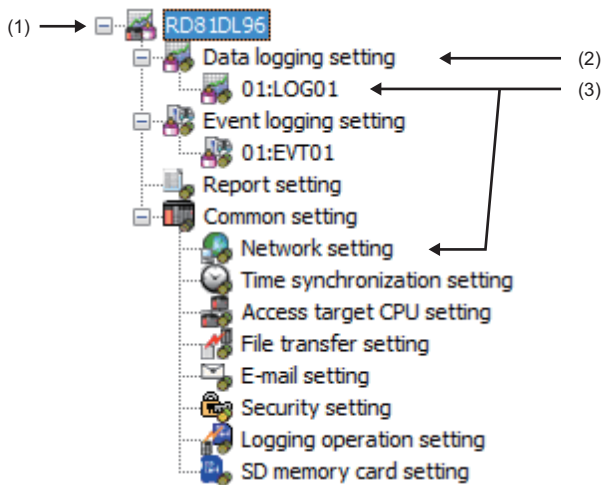

- (1) Project root
- (2) Setting type
- (3) Item

### ■Item selection

Items are displayed by double clicking each setting type.

Select the displayed item to display the editing screen for the selected item on the detailed setting editing screen.

### ■Add item

Select the setting type, and select [Edit] ⇒ [Add item] to add the item.

When the item is added normally, it is automatically selected and the editing screen switches to the one for the added item.

### ■Delete item

Select the item to be deleted, and select [Edit] ⇒ [Delete item] to delete the item.

### ■Replicating item

Select the item to copy, and select [Edit] ⇒ [Replicate item] to add a copy of the item.

When the item is added normally, it is automatically selected and the editing screen switches to the one for the added item.

# Parameter settings

Configure the mode setting of the high speed data logger module and default operation setting in the parameter setting of an engineering tool .

For details on parameter settings, refer to the following manual.

📖 MELSEC iQ-R High Speed Data Logger Module User's Manual(Application)

## Startup method

### Operating procedure

1. Select [MELSOFT] ⇒ [GX Works3]<sup>\*2</sup> ⇒ [GX Works3] from Windows Start<sup>\*1</sup>.

\*1 Select [All apps] on the Start screen or [Start] ⇒ [All Programs]/[All apps].

\*2 Does not appear in Windows 8 or later.

## Parameter settings

### Operating procedure

1. Create a new project.

🖱️ Select [Project] ⇒ [New].

2. Select "Series", "Type", and "Program Language", and click the [OK] button.

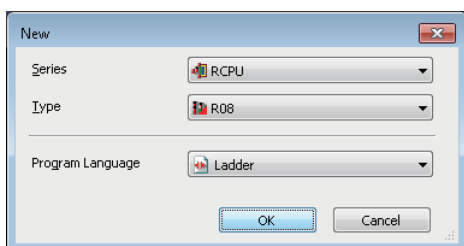

3. Set whether to use module labels, click the [OK] button.

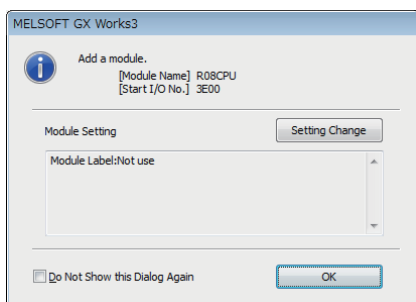

4. Displays the "Add New Module" screen.

🖱️ Select [Parameter] on the Navigation window, right-click the "Module Information" and select [Add New Module].

5. Add the high speed data logger module.

| Item                        | Description   |
|-----------------------------|---|
| Module Type                 | Select "Information Module".  |
| Module Name                 | Select "RD81DL96".  |
| Mounting Slot No.           | Select the slot No. where the high speed data logger module is mounted.   |
| Start I/O No. Specification | Select "Not Set" when not specifying the start I/O number of the high speed data logger module, otherwise, select "Set".  |
| Start I/O No.               | When "Set" is selected in "Start I/O No. Specification", enter the start I/O number of the high speed data logger module. |

6. Set whether to use module labels, click the [OK] button.

7. Set the module parameter of the high speed data logger module.

☞ [Navigation window] ⇒ [Parameter] ⇒ [Module Information] ⇒ [RD81DL96]

8. After completing the parameter settings, write the settings to the CPU module from the engineering tool.

9. Reflect the settings by resetting or powering OFF to ON the CPU module.

## 4.2 SD Memory Card

This section shows the SD memory cards inserted and used in the high speed data logger module.  
For available SD memory cards and precautions, refer to the following sections.

☞ Page 71 SD memory card (sold separately, required)

☞ Page 13 Considerations for using SD memory cards

### Operations for inserting SD memory card

This section shows the method for inserting the SD memory card.

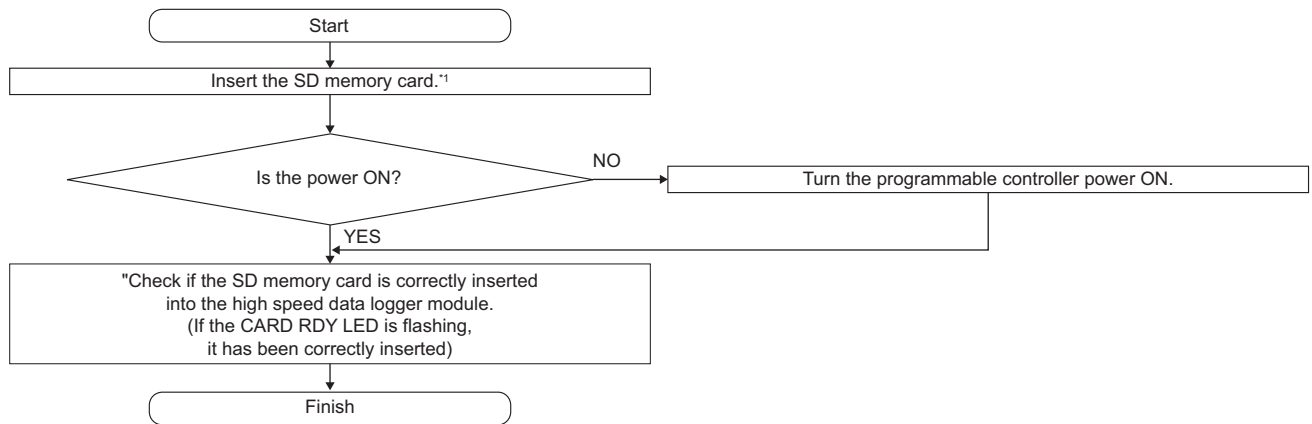

\*1 ☞ Page 66 Insertion procedure

#### Point

The SD memory card insertion status can be checked with the input signal.  
If 'SD memory card status' (X1) is ON, the SD memory card has been correctly inserted.



# Operations for removing and reinserting SD memory card

When removing an SD memory card, always stop file access following the procedure below.

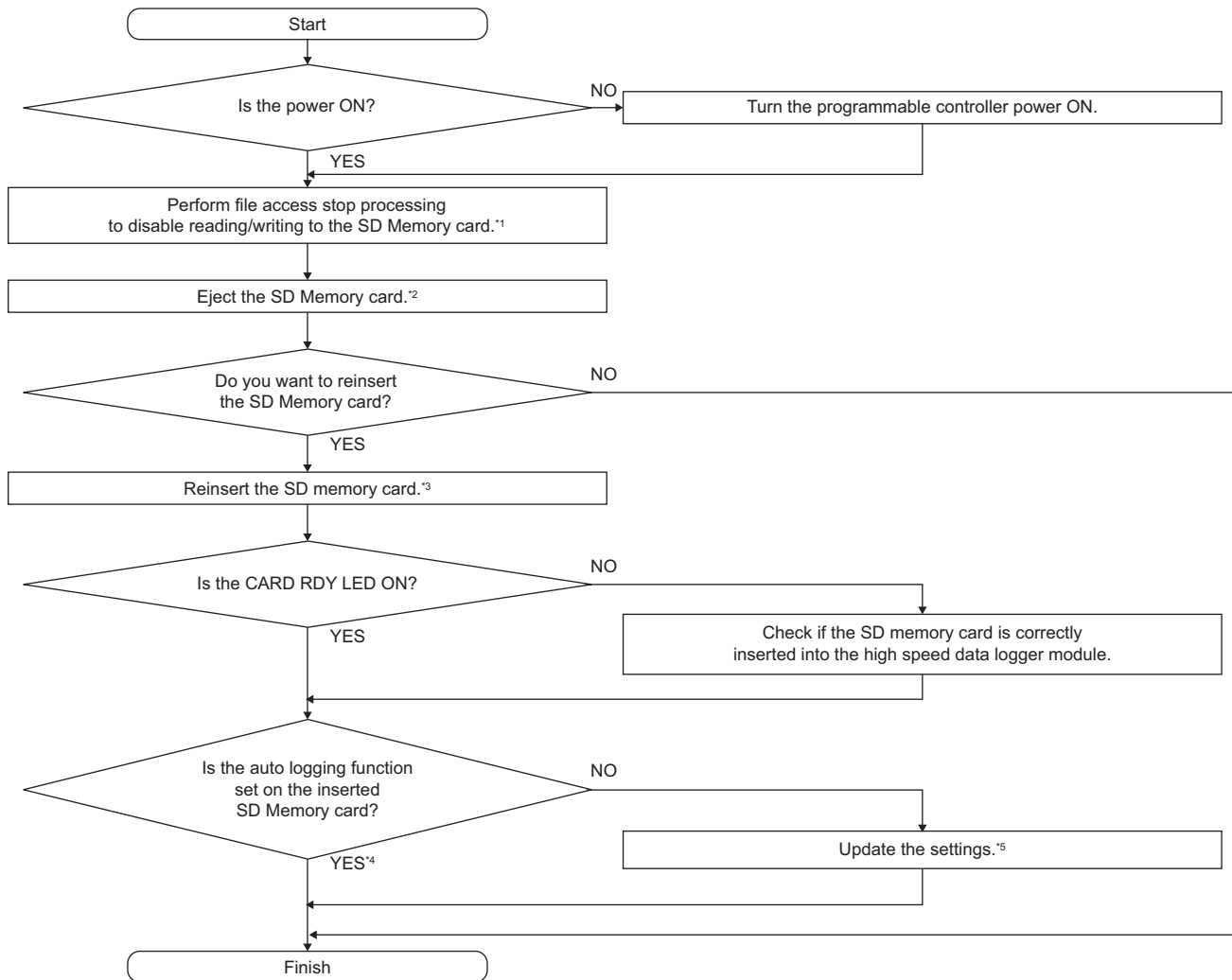

\*1 Page 65 File access stop processing method

\*2 Page 66 Removal procedure

\*3 Page 66 Insertion procedure

\*4 When inserting the SD memory card on which the auto logging function has been set, the logging starts as the card is inserted.

\*5 Update the settings in "Module diagnostics" of the configuration tool. ( MELSEC iQ-R High Speed Data Logger Module User's Manual(Application))

## Point

- Not following the procedure shown above may cause a loss of logging data during processing, corruption of data, or occurrence of a file system error on the SD memory card while accessing.
- If an error occurs on the SD memory card, refer to the following manual.  
( MELSEC iQ-R High Speed Data Logger Module User's Manual(Application))
- High speed data logger module settings are saved on the SD memory card. Therefore, the IP address of the high speed data logger module returns to the initial status (192.168.3.3) when turning the power OFF to ON or resetting the CPU module without a SD memory card inserted in the module or without the settings written to the SD memory card.

As necessary, read the current settings before removing the SD memory card and after replacing the card, promptly write those settings to the new card.

# Operations for replacing new SD memory card

When replacing the new SD memory card, always stop file access following the procedure below.

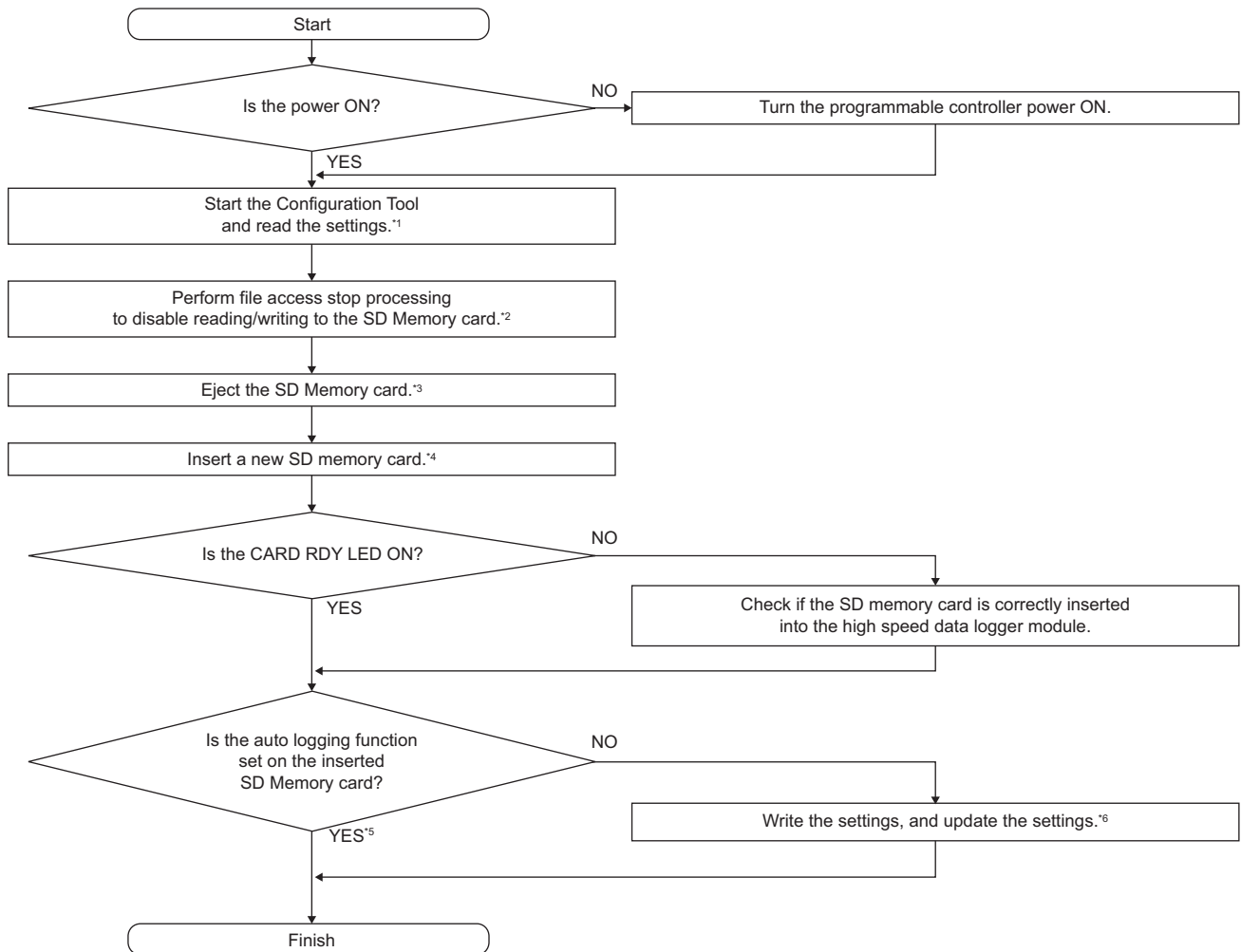

\*1 Can be omitted if auto logging function is set on a newly inserted SD memory card.

\*2 Page 65 File access stop processing method

\*3 Page 66 Removal procedure

\*4 Page 66 Insertion procedure

\*5 When inserting the SD memory card on which the auto logging function has been set, the logging starts as the card is inserted.

\*6 Update the settings in "Module diagnostics" of the configuration tool. ( MELSEC iQ-R High Speed Data Logger Module User's Manual(Application))

## Point

- Not following the procedure shown above may cause a loss of logging data during processing, corruption of data, or occurrence of a file system error on the SD memory card while accessing.
- If an error occurs on the SD memory card, refer to the following manual.  
( MELSEC iQ-R High Speed Data Logger Module User's Manual(Application))
- High speed data logger module settings are saved on the SD memory card. Therefore, the IP address of the high speed data logger module returns to the initial status (192.168.3.3) when turning the power OFF to ON or resetting the CPU module without a SD memory card inserted in the module or without the settings written to the SD memory card.  
As necessary, read the current settings before removing the SD memory card and after replacing the card, promptly write those settings to the new card.

# File access stop processing method

The following are the methods to stop file access.

- Switch operation on the front of the module
- I/O (X/Y) operation
- Online operation of the configuration tool

## Method using the switch operation in the front of the module

1. Press the SD memory card lock switch for one second or more.
2. Check if the CARD RDY LED is turned OFF.

## Method using I/O (X/Y) operation

1. Turn OFF to ON the 'File access stop request' (Y2).
2. Check if the 'File access status' (X2) is turned ON from OFF, or check if the CARD RDY LED is turned OFF.

To turn ON the 'file access status' (X2), the 'SD memory card status' (X1) is OFF.

Turn ON to OFF the 'File access stop request' (Y2) if required.

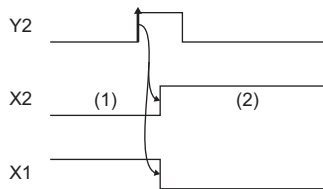

(1) In operation

(2) Stopped

Y2: File access stop request

X2: File access status

X1: SD memory card status

If the file access stop request is executed by mistake, execute the clear file access stop request and the setting renew request.

## Method using online operation of the configuration tool

1. Execute diagnostics.
  - ☞ Select [Online] ⇒ [Diagnostics].
2. Stopping file access.
  - ☞ Select the "Access stop" from "SD memory card operation" on the "SD memory card diagnostics", and click the "Execute" button.

# SD memory card insertion/removal method

Make sure to stop the file access when removing or replacing the SD memory card.

## Insertion procedure

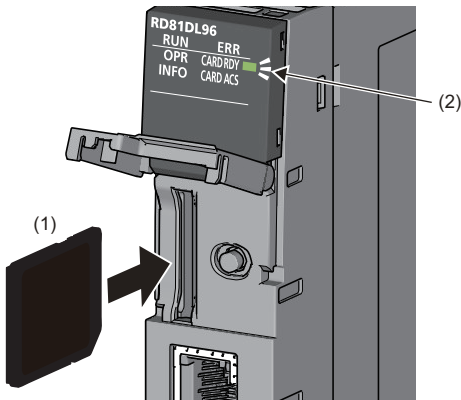

1. Set the cutout part of the SD memory card (1) to the lower side and insert it straight into the SD memory card slot. Make sure it is not uplifted after insertion. Poor contact may cause malfunction.
2. The CARD RDY LED (2) keeps flashing until the SD memory card is ready to be used. Once the CARD READY LED (2) turns ON, the SD memory card can be used.

## Removal procedure

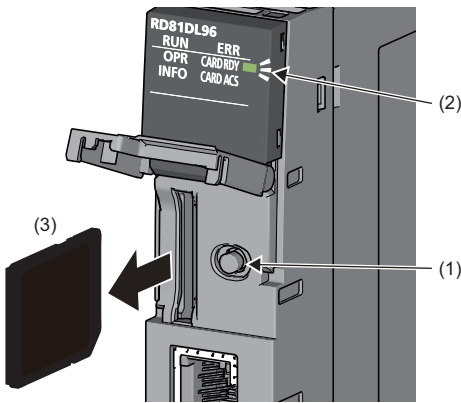

1. Press the SD memory card lock switch (1) for one second or longer to stop the SD memory card access. (Refer to Page 65 File access stop processing method)
2. The CARD RDY LED (2) flashes during the file access stop processing, and it turns OFF after completing the process.
3. Push the SD memory card (3) in once, and pull it out straight.

# 5 SYSTEM CONFIGURATION

This chapter shows the system configuration of the high speed data logger module.

## 5.1 System Configuration

### Overall system configuration

The following figure shows the overall system configuration when using a high speed data logger module.

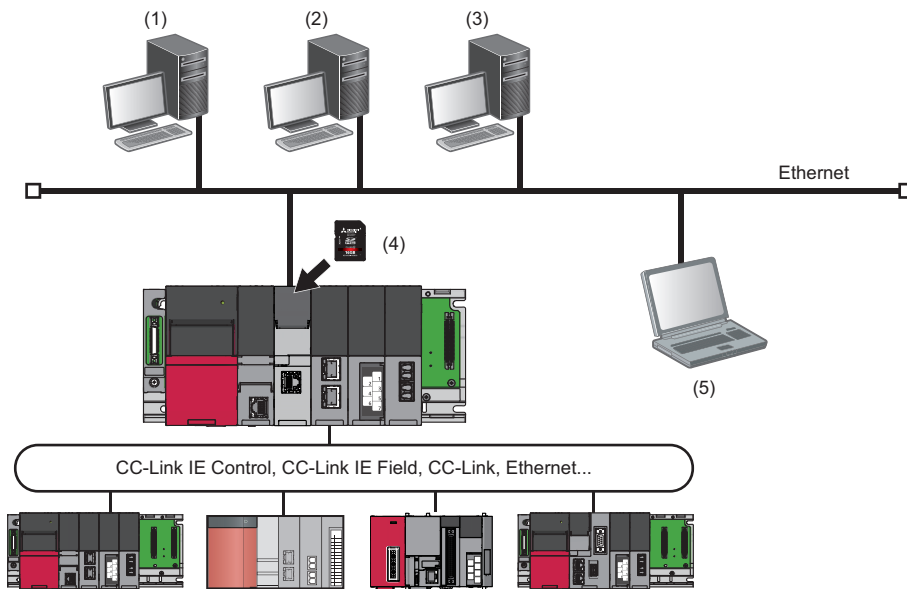

- (1) Mail server \*1
- (2) File server (FTP server, shared folder) \*2
- (3) DHCP server \*3
- (4) SD memory card (sold separately, required)
- (5) Configuration personal computer (configuration tool, GX LogViewer)

\*1 Required when sending e-mail.

\*2 Required when externally saving logged files.

\*3 Required when the IP address of the high speed data logger module is automatically acquired.



For available CPU modules and the number of mountable ones, refer to the following:

MELSEC iQ-R Module Configuration Manual

# Software configuration of the high speed data logger module tool

The following shows the software configuration of the high speed data logger module tool.

| Item   | Description   |
|--|---|
| High speed data logger module tool               | This installer is for installing the following software.<br>• High speed data logger module configuration tool  |
| High speed data logger module configuration tool | This software configures the high speed data logger module.<br>Install on a configuration personal computer.<br>This software can perform online startup by the high speed data logger module without installing it on a configuration personal computer. |

## System configuration when installing

The following shows the system configuration when installing the high speed data logger module tool.

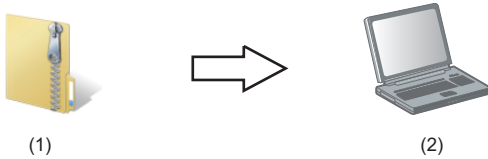

- (1) High speed data logger module tool
- (2) Configuration personal computer

## System configuration for the initial setup, maintenance, and inspection

Connect a high speed data logger module and a configuration personal computer directly to perform an initial setup, maintenance, and inspection. (☞ Page 69 Direct connection, Page 70 Considerations for direct connection)



- (1) High speed data logger module
- (2) Ethernet (twisted pair cable)
- (3) Configuration personal computer

# System configuration during operation

This section shows the system configuration when operating the high speed data logger module.

## Connection via a hub

Connect a high speed data logger module to a personal computer via a hub in a local area network.

When connecting to server personal computers such as FTP server or mail server, it must be connected via a hub.

The IP address of a high speed data logger module needs to be specified.

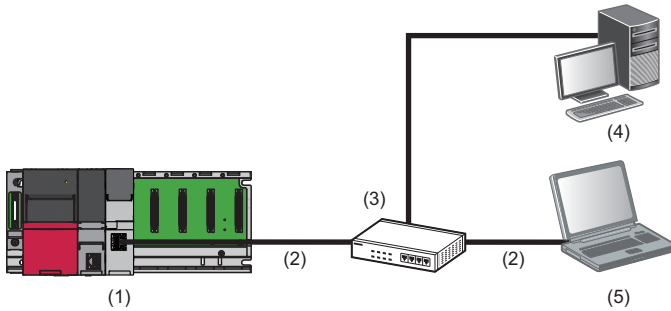

- (1) High speed data logger module
- (2) Ethernet (twisted pair cable)
- (3) Hub
- (4) Server personal computer
- (5) Configuration personal computer

### Restriction

The operation of a high speed data logger module with the following connection methods is not guaranteed.

- Connection using Internet (general public line) (Internet-access service offered by an Internet service provider or a telecommunications carrier)
- Connection using a firewall device
- Connection using a broadband router
- Connection using a wireless LAN

## Direct connection

A high speed data logger module can directly be connected to a configuration personal computer on a 1:1 basis with an Ethernet cable (crossover cable) without a hub.

When maintaining the equipment or monitoring by GX LogViewer in the environments that are not connected with server personal computers, configure the direct connection.

The IP address of a high speed data logger module does not need to be specified for communication. (Broadcast is used.)



- (1) High speed data logger module
- (2) Ethernet (twisted pair cable)
- (3) Configuration personal computer

## Considerations for direct connection

### ■Connecting to a LAN line

Do not perform communication with direct connection by connecting to LAN line.

This may increase the line load and affect any communication of other devices.

### ■Connections which are not direct connections

Do not configure the direct connection in the configuration where a single high speed data logger module and a single configuration personal computer are connected to a hub.

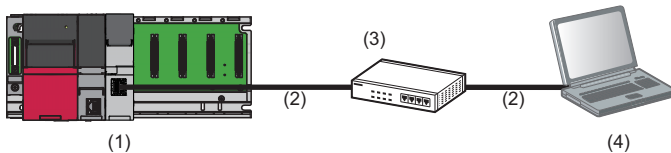

(1) High speed data logger module

(2) Ethernet (twisted pair cable)

(3) Hub

(4) Configuration personal computer

### ■Conditions where communication cannot be established by direct connection

If the following condition is satisfied, the communication by direct connection may not be established. In that case, review the settings of the high speed data logger module and configuration personal computer.

- When all the bits of the high speed data logger module IP address corresponding to the '0' parts of the configuration personal computer subnet mask are ON or OFF

#### Ex.

High speed data logger module IP address: 64.64.255.255

Configuration personal computer IP address: 64.64.1.1

Configuration personal computer subnet mask: 255.255.0.0

- When all the bits of the high speed data logger module IP address corresponding to the host address of each class for the configuration personal computer IP address are ON or OFF

#### Ex.

High speed data logger module IP address: 64.64.255.255

Configuration personal computer IP address: 192.168.0.1

Configuration personal computer subnet mask: 255.0.0.0

- When the high speed data logger module IP address is automatically acquired by DHCP

#### Point

- The IP address of each class are as follow.  
Class A: 0.x.x.x to 127.x.x.x, Class B: 128.x.x.x to 191.x.x.x, Class C: 192.x.x.x to 223.x.x.x
- The host address of each class is the 0 portion below.  
Class A: 255.0.0.0, Class B: 255.255.0.0, Class C: 255.255.255.0

### ■Other considerations

- When the Windows firewall setting of the configuration personal computer is enabled

Disable the Windows firewall setting.

- When multiple IP addresses are enabled in configuration personal computer

In the configuration where multiple IP addresses are enabled at the same time as shown below, do not configure the settings for direct connection.

- When IP address is assigned to the respective configuration personal computer with multiple Ethernet ports
- When a wireless LAN setting is enabled in addition to Ethernet port of the configuration personal computer
- When multiple IP addresses are assigned to one network device (Ethernet port) of a configuration personal computer
- When selecting "Acquire automatically" for the IP address setting in the network setting in the high speed data logger module

Change the IP address settings to "Specify". Or prepare a DHCP server and connect via a hub.



## 5.2 Connection System Equipment

This section shows the equipment that can be connected to the high speed data logger module.

### SD memory card (sold separately, required)

The high speed data logger module requires one SD memory card.

Use one of the following SD memory cards manufactured by Mitsubishi.

| Model         | Description          |
|---------------|----------------------|
| NZ1MEM-2GBSD  | SD memory card 2 GB  |
| NZ1MEM-4GBSD  | SD memory card 4 GB  |
| NZ1MEM-8GBSD  | SD memory card 8 GB  |
| NZ1MEM-16GBSD | SD memory card 16 GB |

When using an SD memory card, make sure to refer to the considerations. (☞ Page 13 Considerations for using SD memory cards)

### Ethernet (twisted pair) cable (sold separately)

The Ethernet cables compliant with IEEE802.3 1000BASE-T/100BASE-TX/10BASE-T standards can be used.

| Transmission speed | Unshielded twisted pair cable (UTP cable)<br>Shielded twisted pair cable (STP cable) |                  |
|--------------------|--|------------------|
|                    | Straight cable   | Crossing cable   |
| 1000 Mbps          | Category 5e or higher  | Category 5e      |
| 100 Mbps           | Category 5 or higher   | Category 5 or 5e |
| 10 Mbps            | Category 3 or higher   | Category 3 to 5e |

When using an Ethernet cable, make sure to refer to the considerations. (☞ Page 76 Wiring considerations)

## 5.3 Operating Environment

This section shows the operating environment for configuration tool.

| Item  | Description   |  |
|---|---|--|
| Personal computer   | —   | A personal computer on which Microsoft® Windows® operates                |
|   | CPU   | Intel® Core™ 2 Duo Processor 2GHz or more recommended                    |
|   | Required memory   | 64-bit OS: Recommended 2GB or more<br>32-bit OS: Recommended 1GB or more |
| Display   | Resolution 1024 × 768 pixels or higher  |  |
| Free hard disk space  | 512 MB or more  |  |
| OS*1,*2<br>(32-bit version and 64-bit version are supported.) | Windows 10 (Home, Pro, Enterprise, Education)*3<br>Windows 8.1*3, Windows 8.1 (Pro, Enterprise)*3<br>Windows 8*3, Windows 8 (Pro, Enterprise)*3<br>Windows 7 (Starter, Home Premium, Professional, Ultimate, Enterprise)*4,*5 |  |
| Interface   | Ethernet port   |  |
| Web browser*6   | Windows Internet Explorer® 8.0<br>Windows Internet Explorer 9.0<br>Windows Internet Explorer 10.0<br>Windows Internet Explorer 11.0   |  |
| Excel®*7,*8<br>(32-bit version is supported.)                 | Microsoft Excel 2010<br>Microsoft Excel 2013<br>Microsoft Excel 2016  |  |

\*1 When the following functions are used, this product may not run properly.

- Application start-up in Windows compatibility mode
- Fast user switching
- Remote desktop
- Windows XP Mode
- Windows Touch or Touch
- Modern UI
- Client Hyper-V
- Virtual desktop
- Tablet mode
- Windows hibernate or standby

\*2 In the following case, the screen of this product may not work properly.

The size of the text and/or other items on the screen are changed to values other than default values (such as 96 DPI, 100%, and 9 pt).

\*3 Disable SmartScreen.

\*4 At the time of online startup of configuration tool, .Net Framework4.5 must be installed.

\*5 Cannot be used if the user is logged on with parental control enabled.

\*6 Required for the configuration tool online startup.

\*7 Required for report setting.

\*8 Install the VBA function.

## 5.4 Considerations for System Configuration

---

This section shows the considerations for system configuration.

### Considerations for using C Controller module

---

The following shows the considerations for using C Controller module.

#### Access target CPU setting

- When the control CPU of the access target network module is a C Controller module, only the control CPU of the network module can be accessed.

#### Network communication route

- When the network module is mounted on the C Controller module, the network module cannot be used as a relay station.

## 5.5 Supported Software Packages

The following table shows the software packages that can be used for the high speed data logger module.

| Software packages | Software version |
|-------------------|------------------|
| GX Works3         | 1.020W or later  |
| GX LogViewer      | 1.54G or later   |

# 6 WIRING

This section shows the method for connecting an Ethernet cable to the high speed data logger module.  
For connectable Ethernet cables, refer to the following section.

 Page 71 Ethernet (twisted pair) cable (sold separately)

## 6.1 Wiring of an Ethernet cable

The following shows connection and disconnection of the Ethernet cable.

### Connecting procedure

1. Check the insertion direction, and insert an Ethernet cable into the Ethernet port on the high speed data logger module until it clicks.
2. Check if the cable securely is connected by pulling it slightly.
3. Check if the SPEED LED lighting status of the Ethernet port connected with the Ethernet cable. ( Page 21 PART NAMES)

#### Point

- The time required from when an Ethernet cable is connected to when the SPEED LED turns ON may vary. Normally, the LED turns ON in a few seconds. However, it may take longer because the linking-up processing is repeated due to the device condition on the line.
- When the SPEED LED does not turn ON, check if the connected Ethernet cable has any failure.
- The SPEED LED is turned OFF when connecting with an Ethernet device on the network of which the transmission rate is 10 Mbps. Check the communication state by executing the PING test etc.

### Disconnecting procedure

1. Pull out the Ethernet cable while pinching a clip on the connector.

### Considerations for 1000BASE-T/100BASE-TX connection

A communication error may occur due to high-frequency noise generated from devices other than the programmable controller depending on the installation environment.

The following shows the measures to be taken on the high speed data logger module side to prevent the influence of high frequency noise.

- Do not bundle a cable with the main circuit or power cable, or do not place it near those lines.
- Place a cable in a duct.
- In the environment where a cable is susceptible to noise, use the STP cable.
- Change the target device connected with the high speed data logger module to one which communicates at 10 Mbps, and decrease the data transmission rate.

## 6.2 Wiring considerations

---

- To establish a reliable system and fully use the functions of the module, a wiring that does not easily receive the effects of noise is required.
- Sufficient safety measures must be taken when constructing the IEEE802.3 1000BASE-T/100BASE-TX/10BASE-T networks.  
Consult a specialist when handling the terminal processing of connection cable, installing trunk cables, etc.
- Use the cables compliant with IEEE802.3 1000BASE-T/100BASE-TX/10BASE-T standards. (☞ Page 71 Ethernet (twisted pair) cable (sold separately))
- For the connection on the target device side, check the specifications of the target device in advance.
- Place an Ethernet cable in a duct or clamp it.  
Otherwise, the dangling cable may swing or inadvertently be pulled. It may cause a module or an Ethernet cable to damage or malfunction due to the poor contact.
- Protect the core wire in the connector of Ethernet cable or the port of the module to prevent touching by hand and sticking dirt or dust.  
If any oil from your hand, dirt or dust sticks the core wire, it may increase the transmission loss and fail a data link.
- Check if the Ethernet cable used is disconnected, a short-circuit is generated, and the connector is properly connected.
- Do not use an Ethernet cable with broken clips.  
Doing so may cause the cable to unplug or malfunction.
- Hold the connector on the Ethernet cable when connecting or disconnecting it.  
If the cable is pulled while being connected to the module, it may cause the module or Ethernet cable to damage or malfunction due to the poor contact.
- Attach the provided connector cover to protect the unused Ethernet port from dirt and dust.
- The maximum segment length of Ethernet cable is 100 m. However, the length may be shorter depending on the use environment of the cable. For details, contact the manufacturer of the cable used.
- The bend radius of the Ethernet cable is limited. For details, check the specifications of the Ethernet cable used.

# 7 INSTALLATION AND UNINSTALLATION

This chapter explains the procedures for installing and uninstalling the high speed data logger module tool.

## Considerations for installation/uninstallation

- Log on to a personal computer as a user with the administrator authority.
- Before the installation, end all running applications on the operating system.  
If software is installed while other applications are running, the product may not run normally.
- Install the software after changing the settings to prevent starting an update program automatically.  
The installer may not run normally because the update program of an operating system or other software, such as Windows Update or Java® update, may start automatically.
- For Windows 8, Windows 8.1, and Windows 10, disable SmartScreen.

## 7.1 Installation Procedure

This section shows the installation procedure of the high speed data logger module tool.

### Operating procedure

1. Decompress the acquired compressed file.
2. Start the installer.  
Double-click the "setup.exe" in the decompressed folder.
3. Enter or select the necessary information according to the instructions shown on the screen.

## Environment after installation

High speed data logger module configuration tool is installed to a specified folder and registered in the start menu. The following table shows the startup method and the maximum number of software, which can start at the same time, after installation.

| Software   | Startup method  | Maximum No. |
|--|---|-------------|
| High speed data logger module configuration tool | Select [MELSOFT] ⇨ [Logging Function] <sup>*2</sup> ⇨ [MELSEC iQ-R High Speed Data Logger Module Configuration Tool] from Windows Start <sup>*1</sup> . | 5           |

\*1 Select [All apps] on the Start screen or [Start] ⇨ [All Programs]/[All apps].

\*2 Does not appear in Windows 8 or later.

## 7.2 Uninstallation Procedure

Uninstall the high speed data logger module configuration tool from the control panel of Windows.

## Environment after uninstallation

The installed folders and the start menu are deleted after the uninstallation.





# 8 OPERATION EXAMPLE

This chapter shows the operation example of simple logging operation in the system configuration including a high speed data logger module.

## 8.1 Preparing for Operation

### Preparing equipment

The following equipment and software is used in the operation examples.

| Device/Software                                  | Production name/Description  | Reference   |
|--|--|---|
| Main base unit                                   | R35B   | □ MELSEC iQ-R Module Configuration Manual               |
| Power supply module                              | R61P   |   |
| CPU module                                       | R08CPU   | Page 33 Accessible CPU modules                          |
| High speed data logger module                    | RD81DL96   | —   |
| SD memory card                                   | NZ1MEM-nGBSD ('n' indicates a number of bytes.)                        | Page 71 SD memory card (sold separately, required)      |
| USB cable  | For connecting personal computer and CPU module                        | □ GX Works3 Operating Manual                            |
| Ethernet cable                                   | For connecting personal computer and the high speed data logger module | Page 71 Ethernet (twisted pair) cable (sold separately) |
| Personal computer                                | Microsoft Windows 7 Professional Operating System (32-bit version)     | Page 72 Operating Environment                           |
| Excel  | Microsoft Excel 2010 (32-bit version)                                  |   |
| GX Works3  | SWnDND-GXW3 ('n' indicates its version.)                               | □ GX Works3 Operating Manual                            |
| GX LogViewer <sup>*1</sup>                       | SWnDNN-VIEWER ('n' indicates its version.)                             | □ GX LogViewer Version 1 Operating Manual               |
| High speed data logger module tool <sup>*1</sup> | SW1DNN-RDLUTL  | —   |
| Sample data for operation examples <sup>*1</sup> | Sequence program (sh081561eng-program_a.gx3)                           | GX Works3 project file                                  |
|  | Layout file (sh081561eng-layout_a.xls)                                 | Excel format file for report                            |

\*1 To acquire the software and sample data, please consult your local Mitsubishi representative.

# System construction

Configure the programmable controller system used in operation examples.

## System configuration

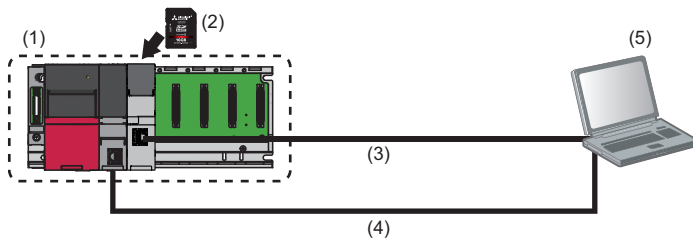

- (1) Programmable controller system
- (2) SD memory card
- (3) Ethernet cable
- (4) USB cable
- (5) Personal computer

## Mounting and wiring modules

### Operating procedure

- 1.** Insert an SD memory card into the high speed data logger module.  
☞ Page 66 SD memory card insertion/removal method
- 2.** Mount all the modules to the main base unit, and wire the power supply.  
📖 MELSEC iQ-R Module Configuration Manual
- 3.** Connect the CPU module and the personal computer with the USB cable.  
📖 MELSEC iQ-R CPU Module User's Manual (Startup)
- 4.** Connect the high speed data logger module and the personal computer with the Ethernet cable.  
☞ Page 75 Wiring of an Ethernet cable

## Activating the system

### Operating procedure

- 1.** Power ON the power supply module.
- 2.** Write the sequence program (sh081561eng-program\_a.gx3) to the CPU module using GX Works3.
- 3.** Switch the mode of the CPU module to 'RUN'.

## 8.2 Logging Data before and after Trigger Occurrence

This section explains how to perform the trigger logging using the equipment shown in the figure below as an example.

### Equipment figure

The following equipment is a winder for packaging film.

The sensor position moves up and down according to variation in the feeding reel speed, and a trigger (error) occurs when the allowable range is exceeded.

Each 100 line (record) of data before and after the trigger occurrence is saved in one file.

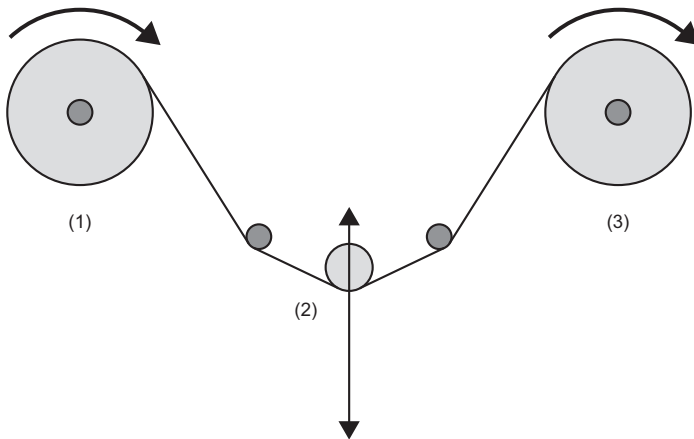

- (1) Feeding reel
- (2) Sensor (The sensor position moves up and down by the film slack.)
- (3) Winding reel

### Operation flow

Perform the operations in the order below.

#### 1. Data logging settings (trigger logging)

Configure the data logging settings with the configuration tool.

#### 2. Write settings

Write the data logging settings to the high speed data logger module.

#### 3. Graphical display of data

Display logged data in a graph using GX LogViewer, and check the values.

# Data logging settings (trigger logging)

Configure the data logging settings with the configuration tool.

## Start the configuration tool

1. Start the configuration tool.

Select [All Programs] ⇒ [MELSOFT] ⇒ [Logging Function] ⇒ [MELSEC iQ-R High Speed Data Logger Module Configuration Tool] from Windows Start.

## Configure the data logging settings

1. Click the [Data logging setting] button.

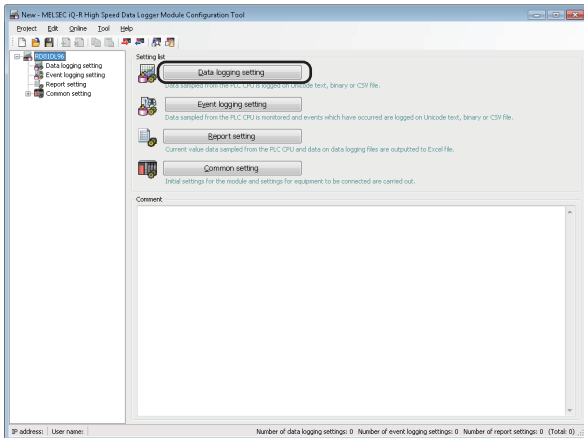

2. Click the [Edit] button.

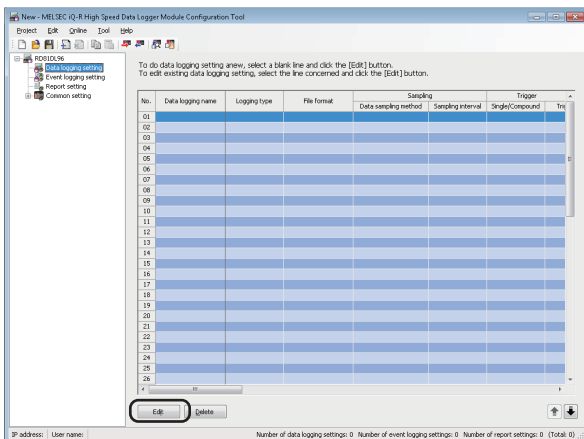

3. Select "Trigger logging" for the logging type, "CSV file" for the file format, and "Output lines before and after the trigger", then click the [Next] button.

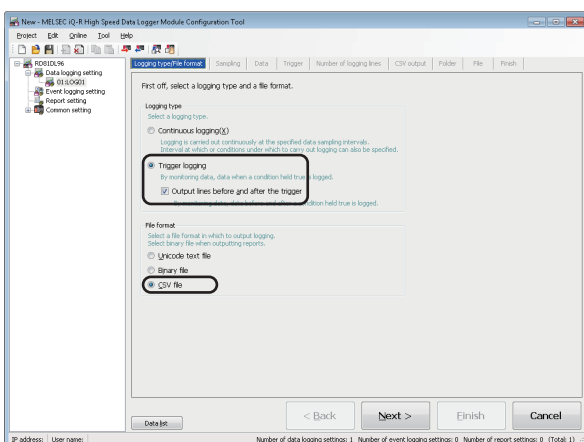

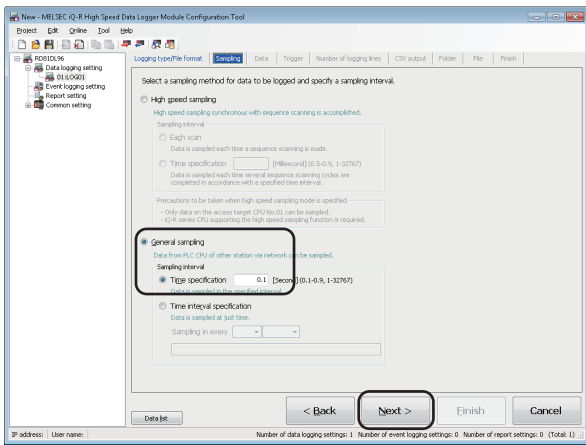

4. Enter '0.1' for the time specification of "General sampling", and click the [Next] button.

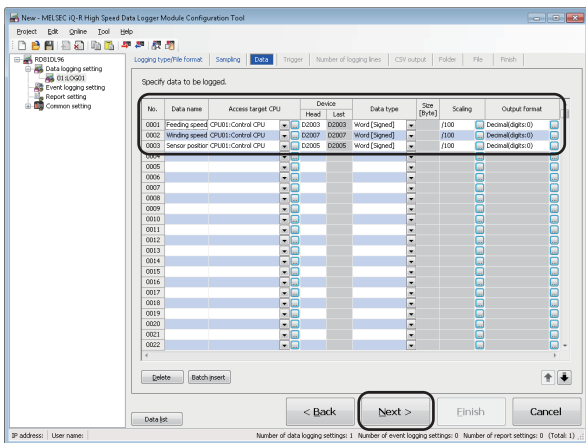

5. Set each setting item according to the following table, and click the [Next] button.

| Data name       | Device (Head) | Scaling |
|-----------------|---------------|---------|
| Feeding speed   | D2003         | /100    |
| Winding speed   | D2007         | /100    |
| Sensor position | D2005         | /100    |

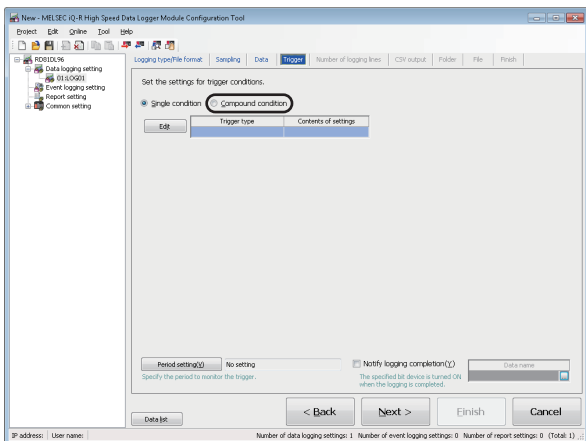

6. Select "Compound condition".

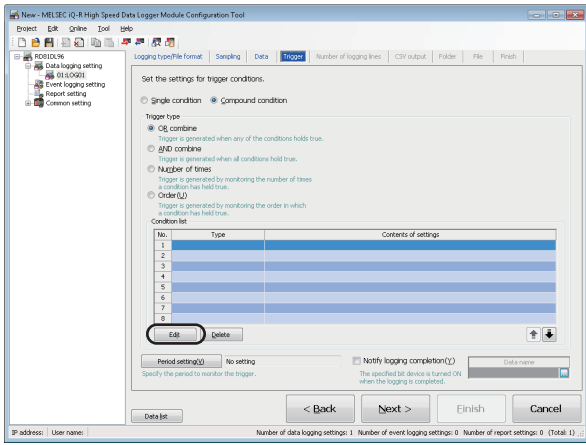

7. Click the [Edit] button.

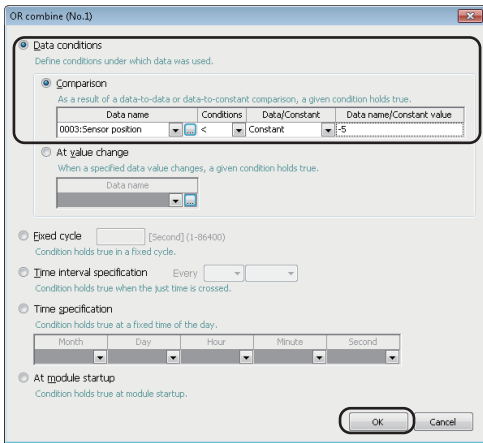

8. Set each setting item according to the following table, and click the [OK] button.

| Data name            | Conditions | Data/Constant | Data name/Constant value |
|----------------------|------------|---------------|--------------------------|
| 0003:Sensor position | <          | Constant      | -5                       |

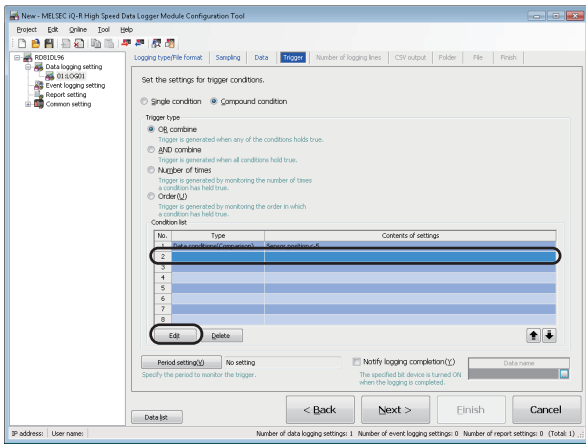

9. Select the second line in the condition list, and click the [Edit] button.

10. Set each setting item according to the following table, and click the [OK] button.

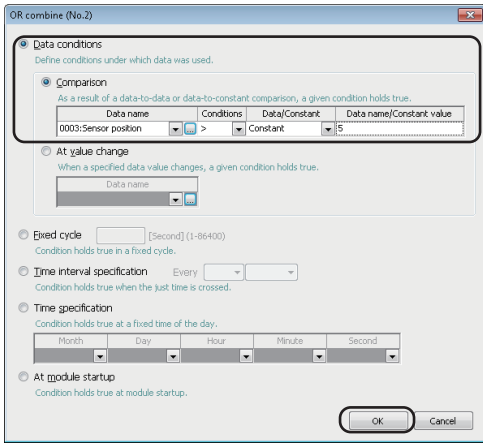

| Data name            | Conditions | Data/Constant | Data name/Constant value |
|----------------------|------------|---------------|--------------------------|
| 0003:Sensor position | >          | Constant      | 5                        |

11. Click the [Next] button.

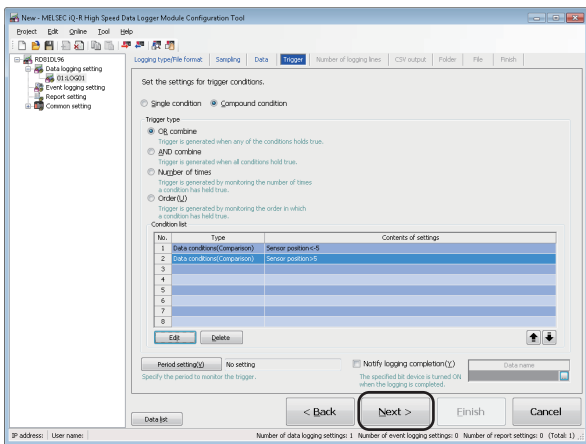

12. Enter '100' for "Before trigger" and "After trigger", and click the [Next] button.

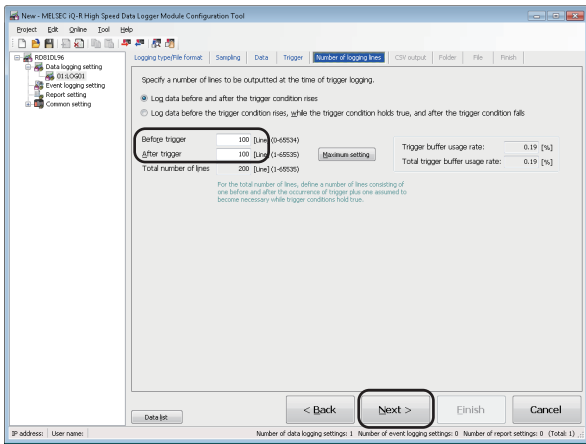

13. Click the [Next] button.

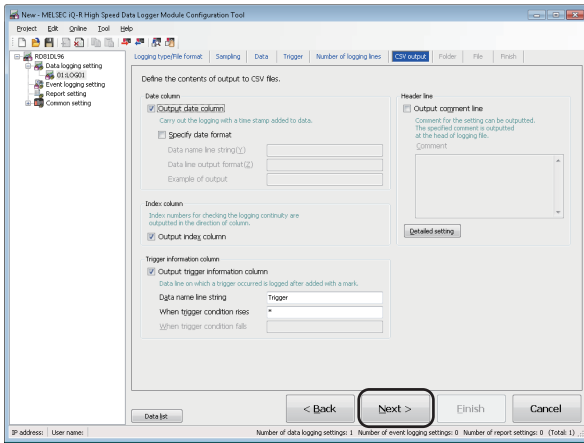

14. Enter 'Trigger\_LOG' for the setting type folder name, and click the [Next] button.

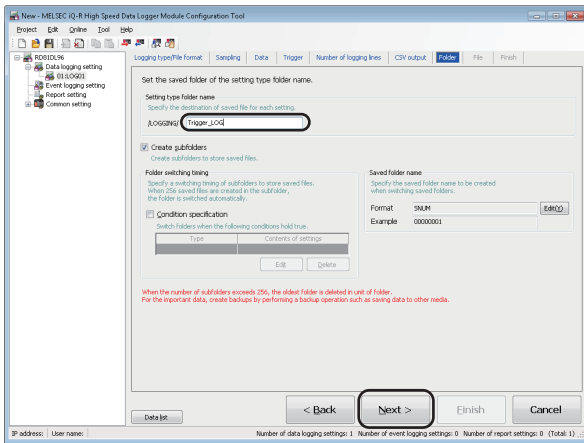

15. Select "Trigger logging unit" and enter '5' for the number of saved files, then click the [Edit] button.

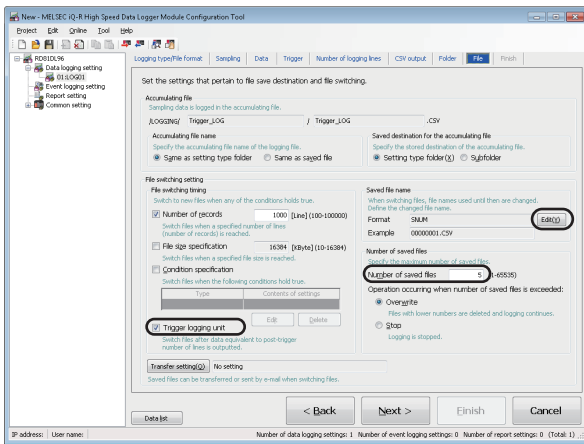

16. Select "Add the name", and click the [OK] button.

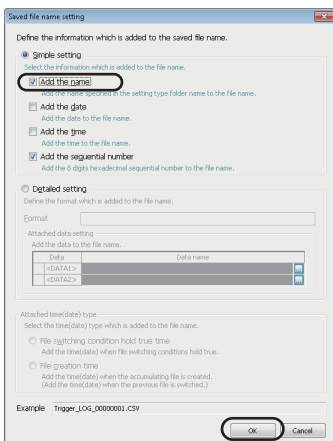



17. Click the [Next] button.

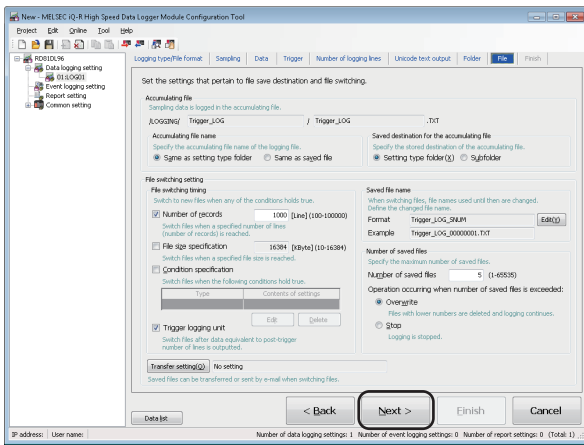

18. Enter 'Winder (Control data)' for the data logging name, and click the [Finish] button.

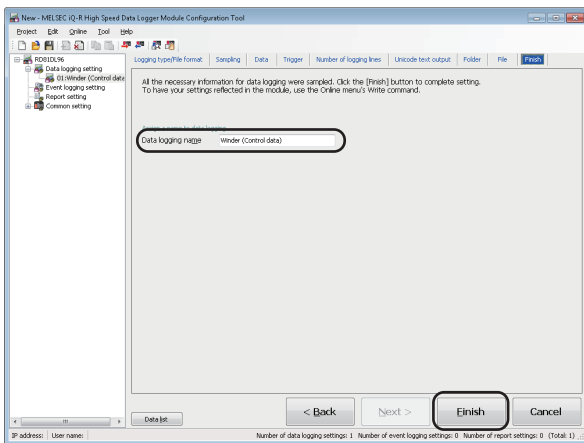

# Write settings

Write the data logging settings to the high speed data logger module.

## Specify the target module

1. Select [Online] ⇒ [Transfer setup].

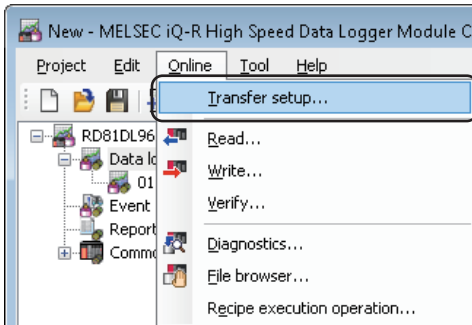

2. Select "Direct connection", and click the [Communication test] button.

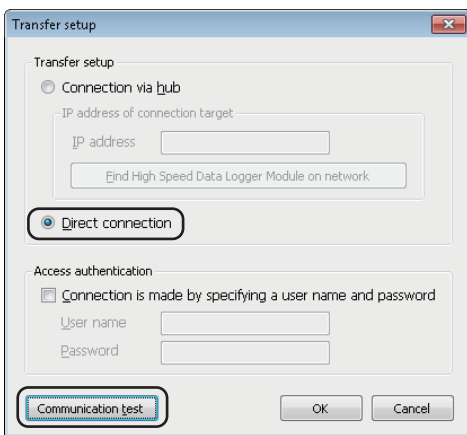

3. Click the [OK] button.

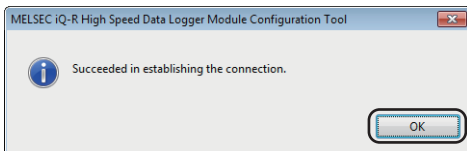

4. Click the [OK] button.



## Write the settings

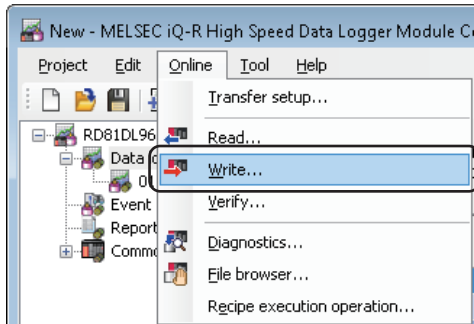

1. Select [Online] ⇒ [Write].

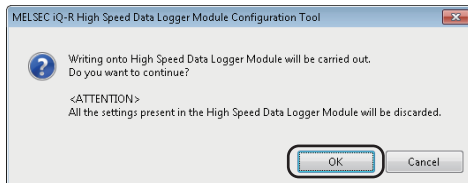

2. Click the [OK] button.

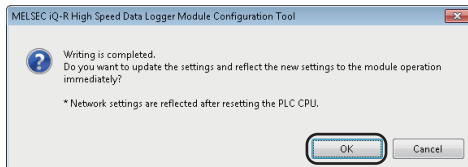

3. Click the [OK] button.

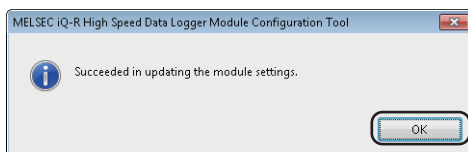

4. Click the [OK] button.

# Graphical display of data

Display logged data in a graph using GX LogViewer, and check the values.

## Start GX LogViewer

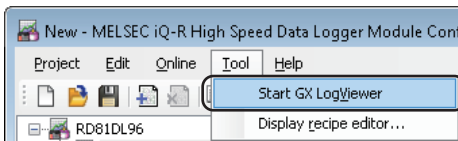

1. Select [Tool] ⇒ [Start GX LogViewer].  
GX LogViewer is started.

## Specify the data to be displayed

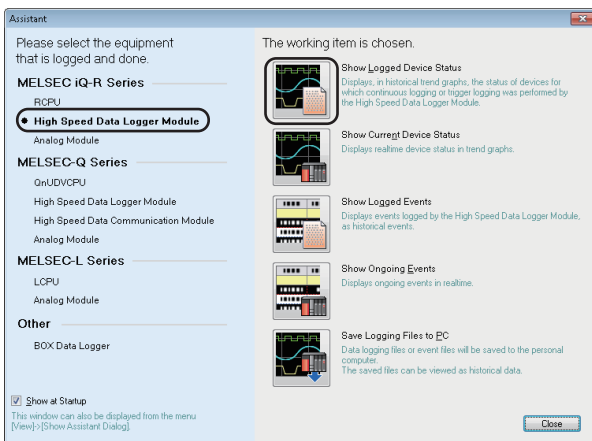

1. Select "High Speed Data Logger Module" of "MELSEC iQ-R Series", and click the icon of "Show Logged Device Status"

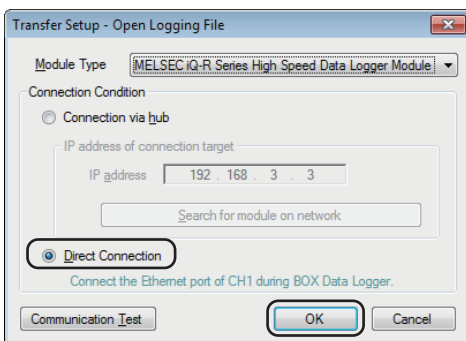

2. Select "Direct Connection", and click the [OK] button.

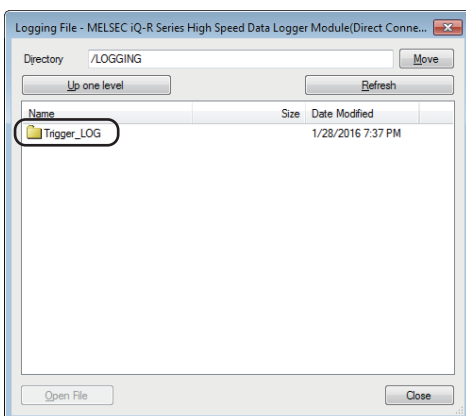

3. Double-click each folder in the following order:  
"Trigger\_LOG" → "00000001"

### Point

Click the [Refresh] button when the folder is not displayed in the list.

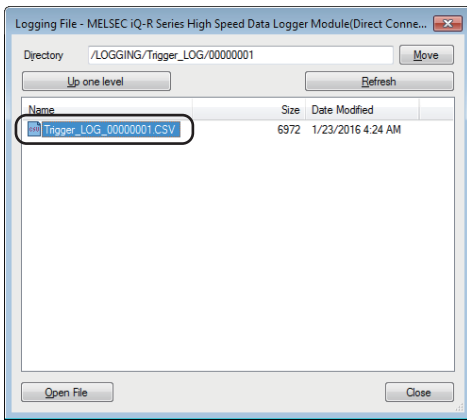

4. Select the displayed CSV file, and click the [Open File] button, then click the [Close] button.

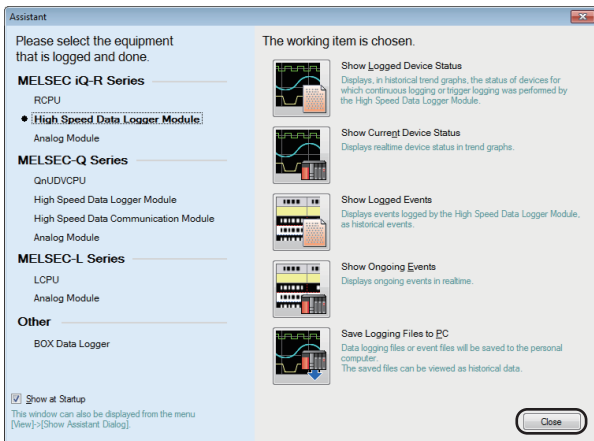

5. Click the [Close] button.

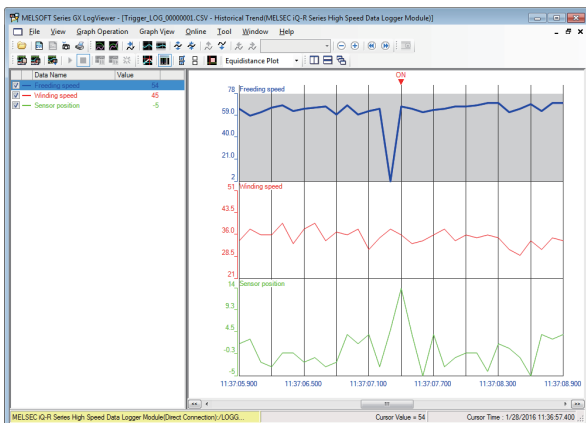

The data specified as target data in the data logging settings are displayed in the graph legend area and the graph area.

**Point**

Note that, in this operation examples, the background color was changed to white by the graph properties ([Graph View] ⇒ [Graph Properties]).

Colors of graph lines can be also changed in graph properties.

## Display multiple cursors

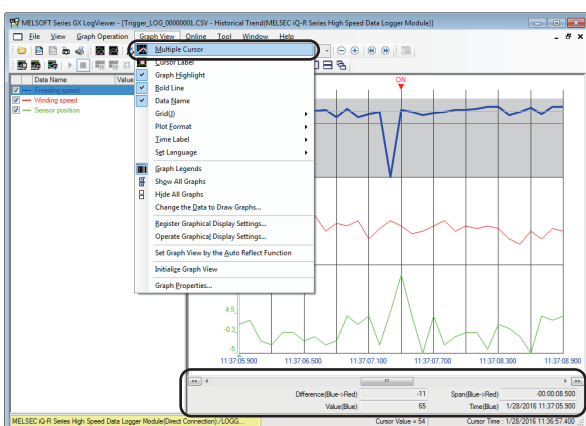

1. Select [Graph View] ⇒ [Multiple Cursor]. The difference information area is displayed.

## Check data using the cursors

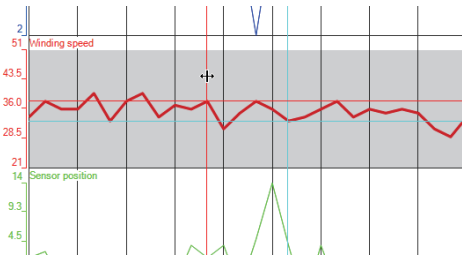

1. Select a graph. Move the red and blue cursors, located at the left edge of the graph, to the desired positions and check their respective values.

### Point

For an easier operation, select [Move Red Cursor Here] or [Move Blue Cursor Here] from the menu displayed by right-clicking on a graph area.

2. Check the differences of respective values and times in the difference information area at the lower area of the screen.

The elapsed time and the value difference between the two cursors (blue to red) are displayed.

In addition, the value and time of each cursor's position are also displayed.

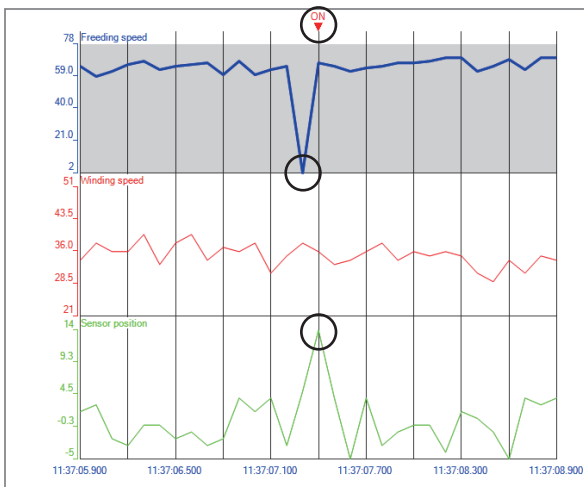
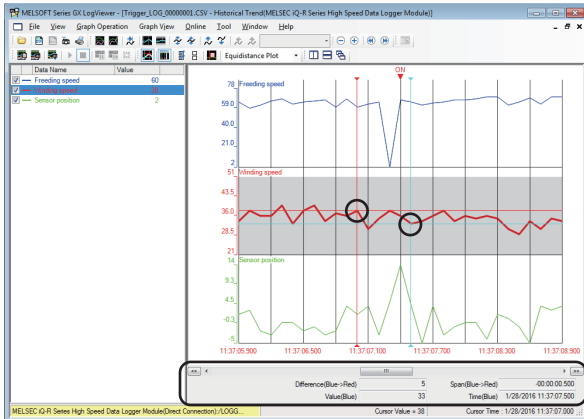

3. Analyze the cause of error from the graphs

- The sensor position rose rapidly, and a trigger occurred.
- The feeding speed drastically decreased immediately before the rise in sensor position, and thus, this could have caused the trigger.

# 8.3 Creating Reports from Continuously Logged Data

This section explains continuous logging function and report creation using Xbar-R management chart as an example.

## Equipment figure

The film thickness (measured data) is measured at four points, and output it to the report (Excel format) named Xbar-R management chart.

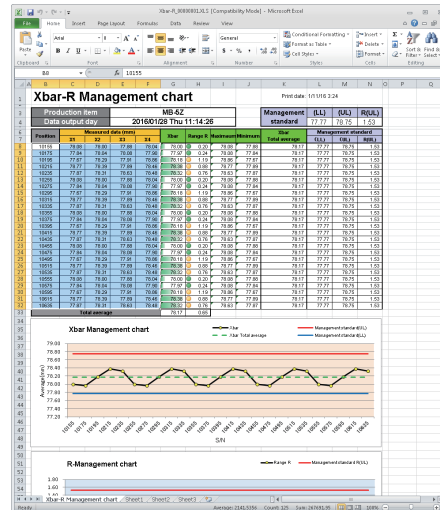
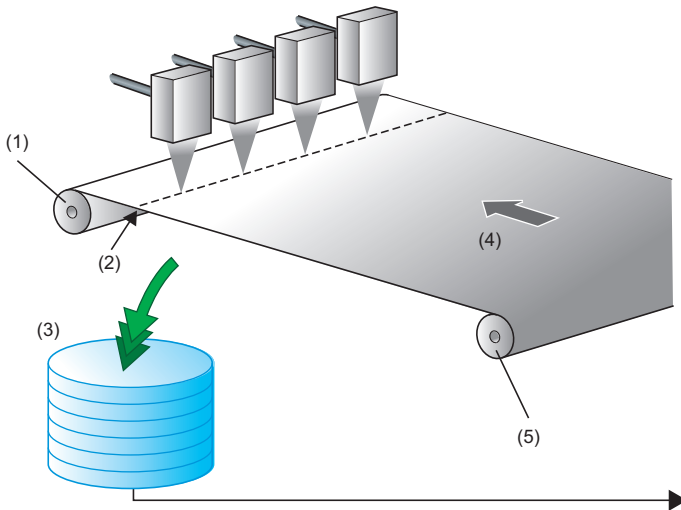

- (1) Winder
- (2) Position (length from the core of the feeder)
- (3) Logging data
- (4) Direction
- (5) Feeder

## Operation flow

Perform the operations in the order below.

- 1. Data logging settings (continuous logging)**  
Configure the data logging settings with the configuration tool.
- 2. Report settings**  
Configure the report settings with the configuration tool.
- 3. Write settings**  
Write the data logging settings and the report settings to the high speed data logger module.
- 4. Check created report**  
Check the report created in an SD memory card which is inserted in the high speed data logger module on Excel.

# Data logging settings (continuous logging)

Configure the data logging settings with the configuration tool.

## Start the configuration tool

1. Start the configuration tool.

Select [All Programs] ⇒ [MELSOFT] ⇒ [Logging Function] ⇒ [MELSEC iQ-R High Speed Data Logger Module Configuration Tool] from Windows Start.

## Configure the data logging settings

1. Click the [Data logging setting] button.

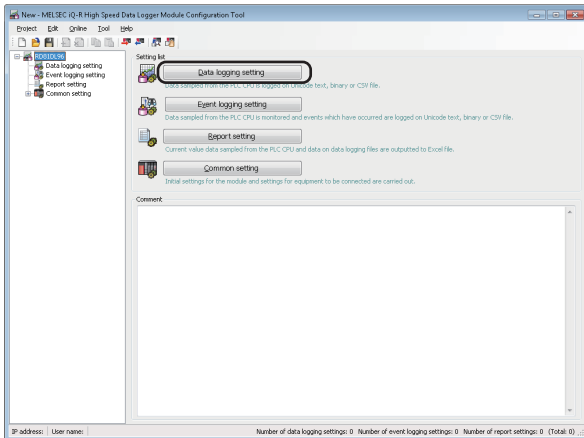

2. Click the [Edit] button.

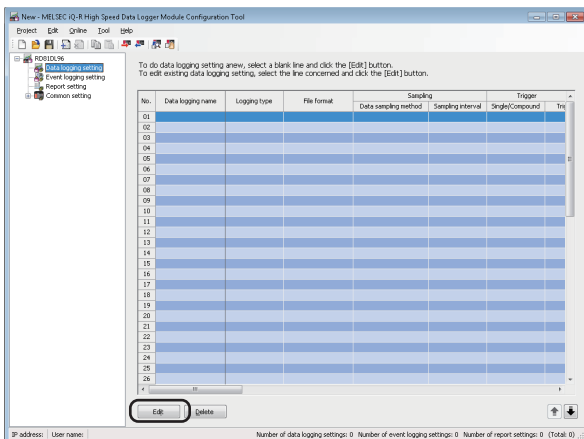

3. Select "Continuous logging" for logging type, and "Binary file" for file format, then click the [Next] button.

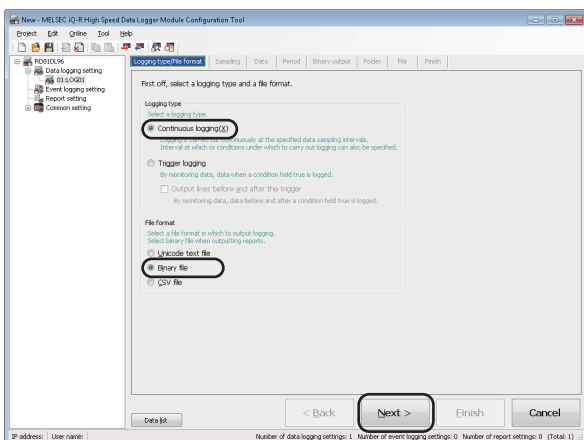



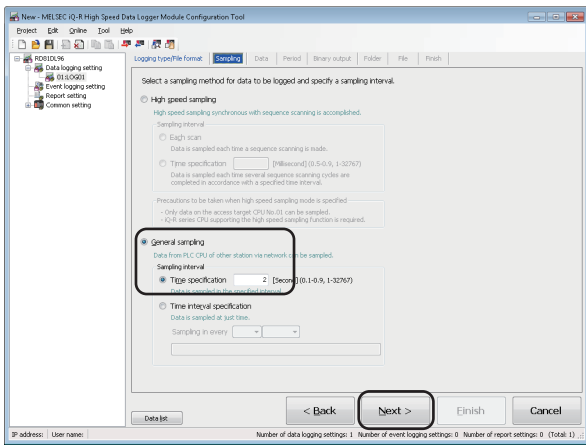

4. Enter '2' for the time specification of "General sampling", and click the [Next] button.

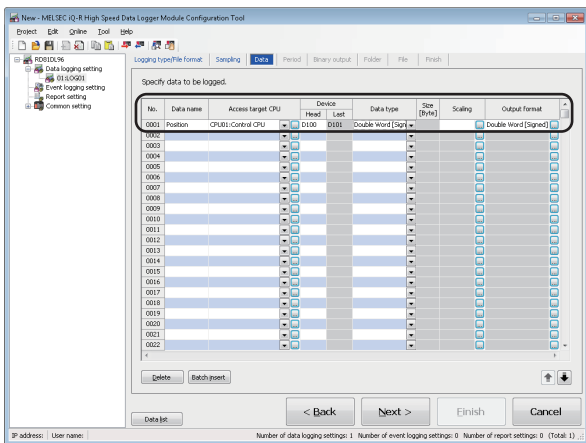

5. Set each setting item according to the following table.

| Data name | Device (Head) | Data type            |
|-----------|---------------|----------------------|
| Position  | D100          | Double Word [Signed] |

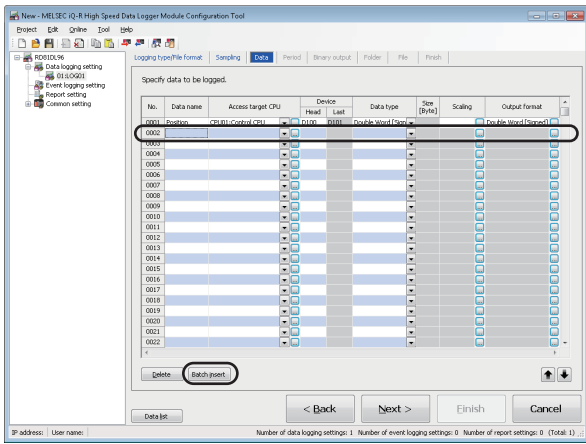

6. Select the second line in the data list, and click the [Batch insert] button.

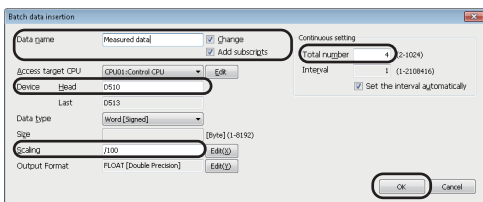

7. Set each setting item according to the following table, and click the [OK] button.

| Setting item       |                | Setting content |
|--------------------|----------------|-----------------|
| Data name          | —              | Measured data   |
|                    | Change         | Select          |
|                    | Add subscripts | Select          |
| Device (Head)      |                | D510            |
| Scaling            |                | /100            |
| Continuous setting | Total number   | 4               |

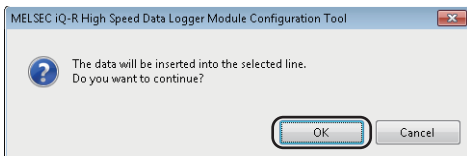

8. Click the [OK] button.

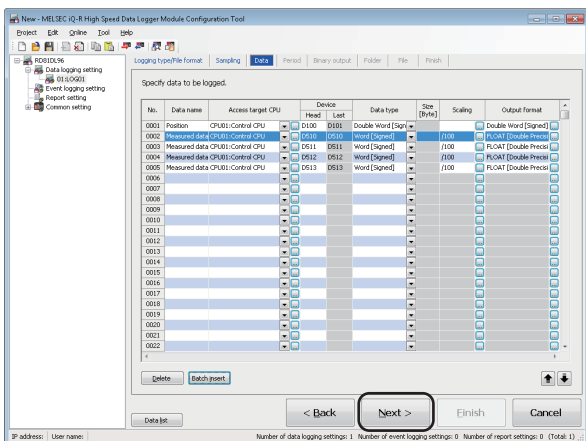

9. Click the [Next] button.

10. Click the [Next] button.

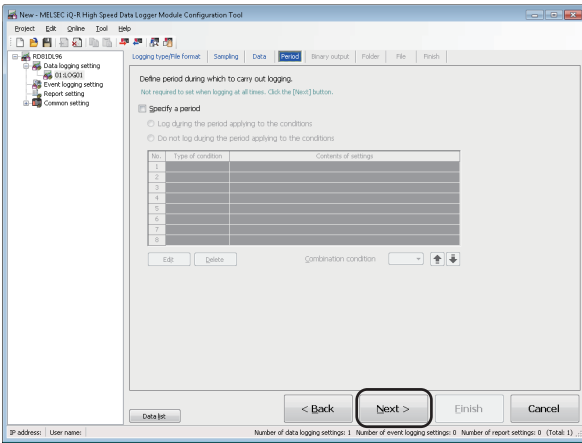

11. Click the [Next] button.

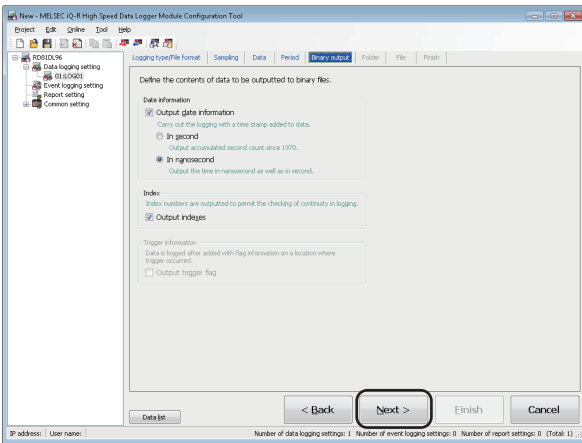

12. Enter 'Xbar-R' for the setting type folder name, and click the [Next] button.

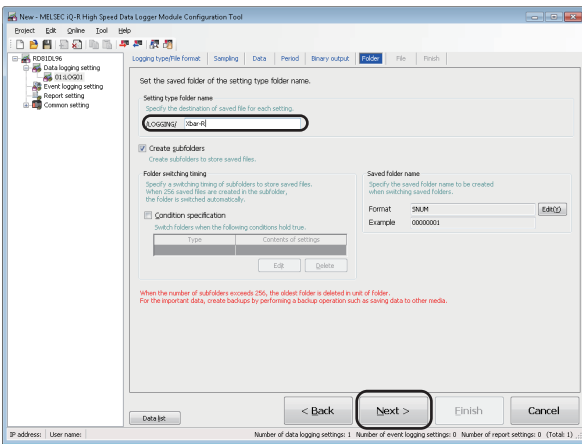

13. Select "Condition specification", and click the [Edit] button.

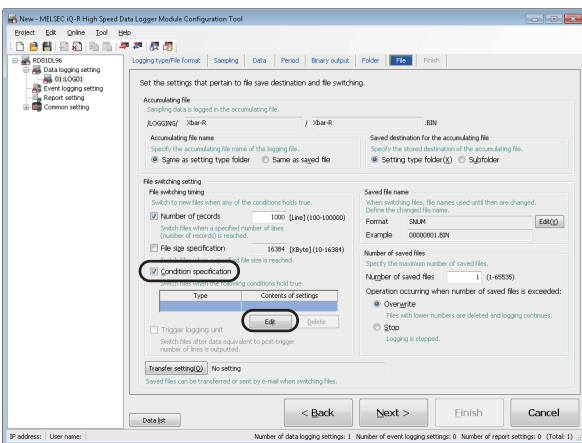

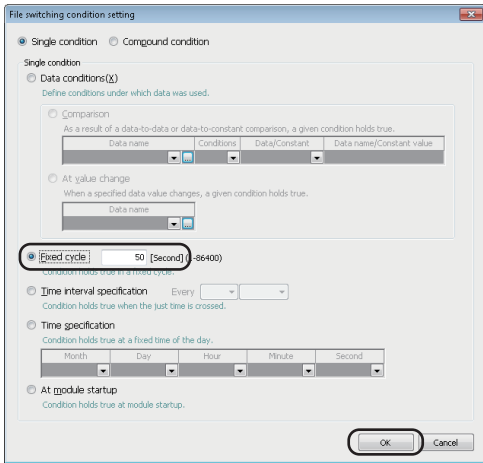

14. Select "Fixed cycle", enter '50', and click the [OK] button.

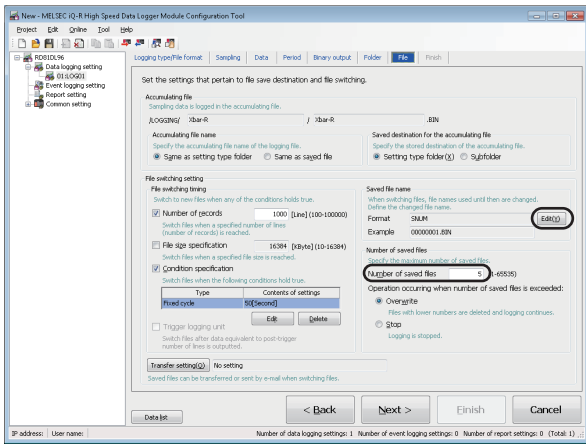

15. Enter '5' for the number of saved files, and click the [Edit] button.

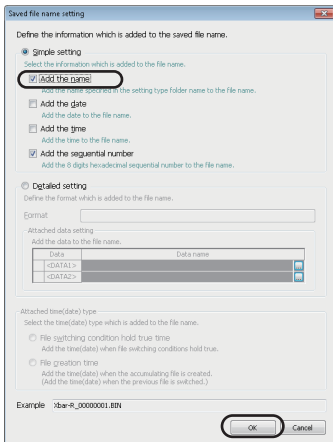

16. Select "Add the name", and click the [OK] button.

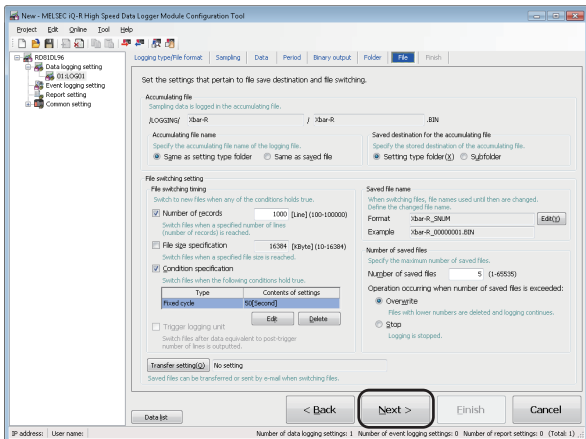

17. Click the [Next] button.

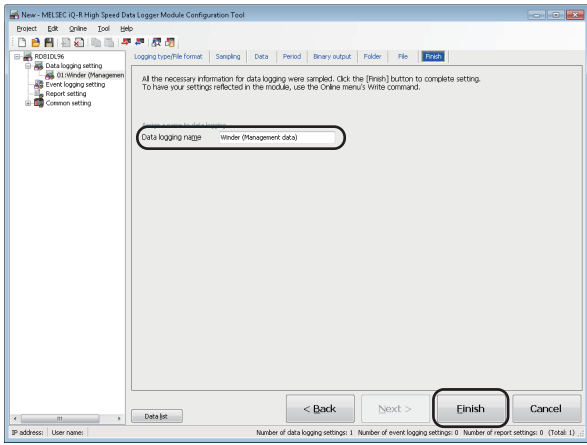

**18.** Enter 'Winder (Management data)' for the data logging name, and click the [Finish] button.

# Report settings

Configure the report settings with the configuration tool.

## Configure the report settings

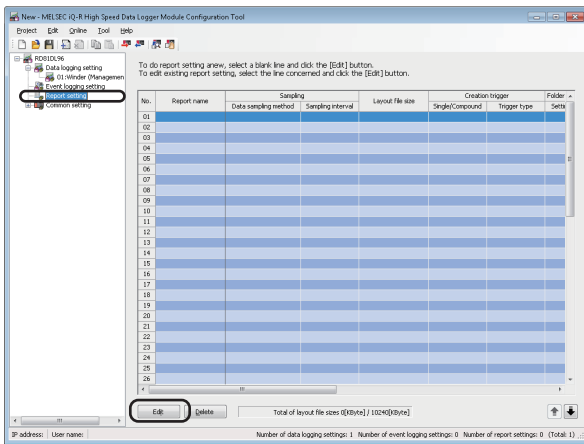

1. Click "Report setting" on the edit items tree, and click the [Edit] button.

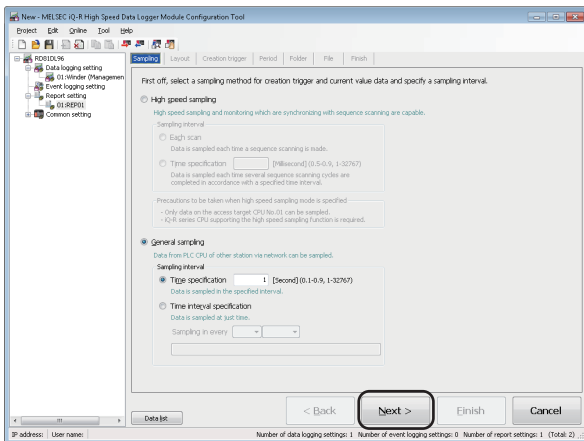

2. Click the [Next] button.

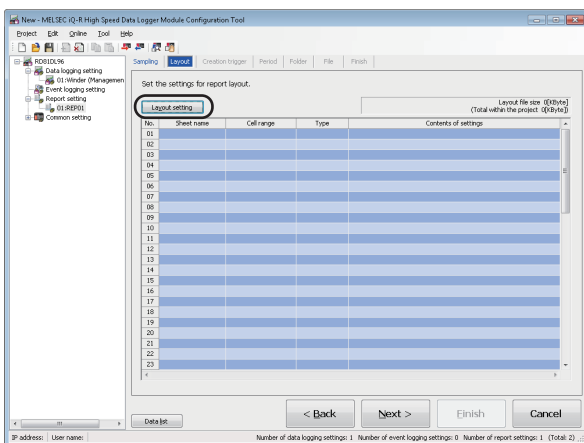

3. Click the [Layout setting] button.

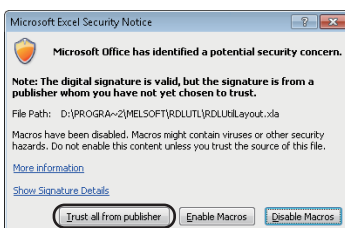

4. Click the [Trust all from publisher] button.

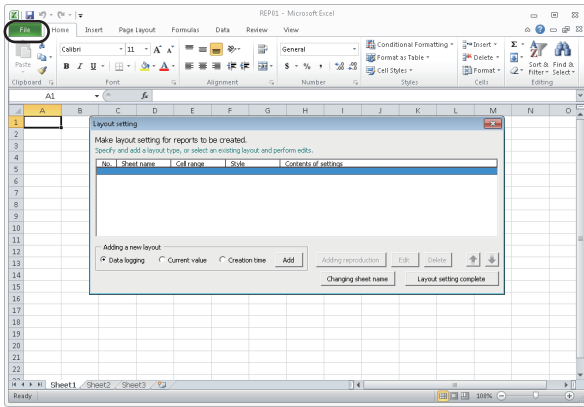

5. Select [File] ⇒ [Open].

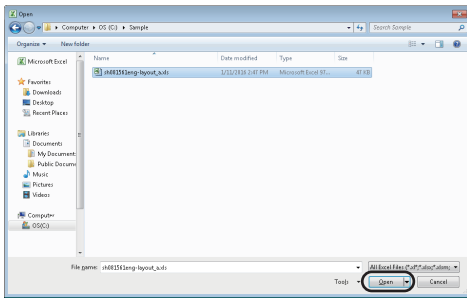

6. Select the acquired "sh081561eng-layout\_a.xls" file, and click the [Open] button.

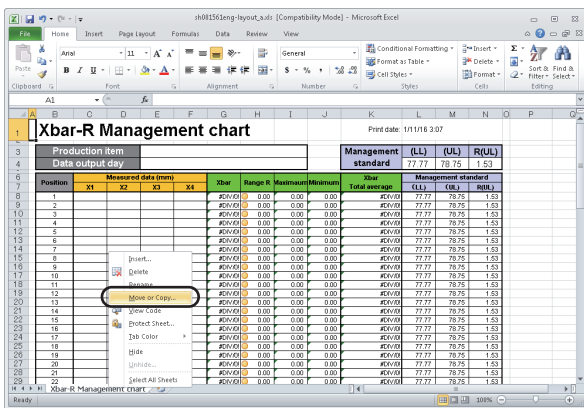

7. Right-click on the sheet tab, and select [Move or Copy].

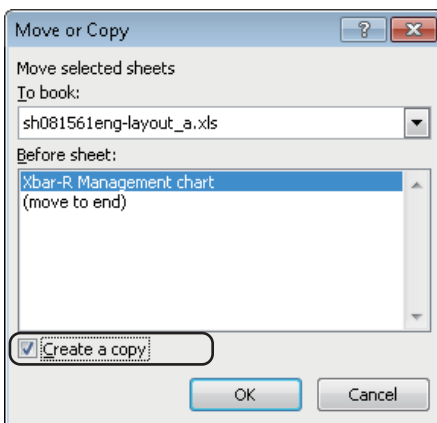

8. Select "Create a copy".

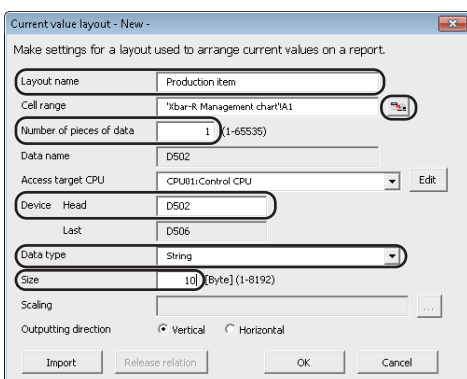
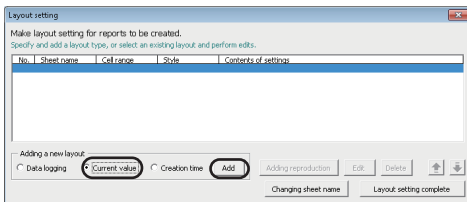
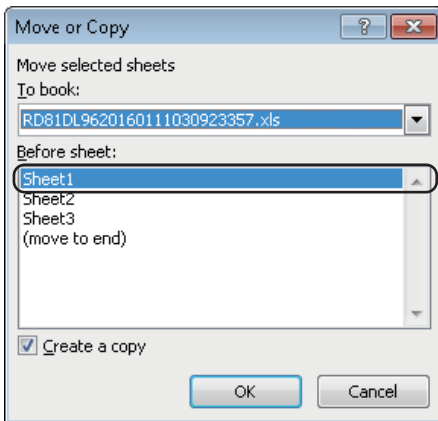
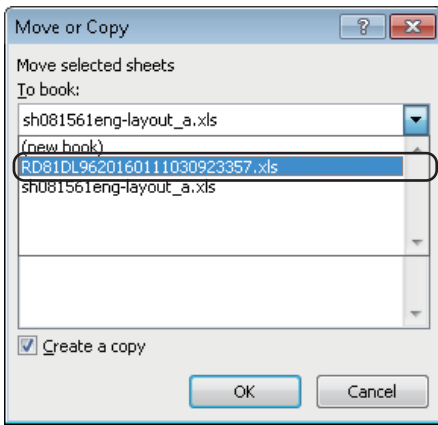

9. Select "RD81DL96YYYYMMDD....xls" from the list of "To book".

10. Select "Sheet1" from the list of "Before sheet", and click the [OK] button.

The "Xbar-R Management chart" sheet is copied to the file "REP01" on which the layout settings are configured. Close "sh081561eng-layout\_a.xls" because it is not used for the later operation.

**Restriction**

A sheet name must be changed by using the [Changing sheet name] button on the "Layout setting" screen.

If the sheet name is changed using other methods, the layout settings will not configure properly.

11. Select "Current value", and click the [Add] button.

12. Set each setting item according to the following table, and click the [OK] button.

| Setting item             | Setting content |
|--------------------------|-----------------|
| Layout name              | Production item |
| Number of pieces of data | 1               |
| Device (Head)            | D502            |
| Data type                | String          |
| Size                     | 10              |



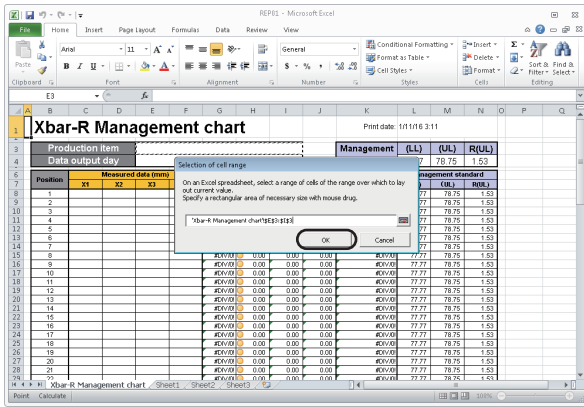

13. Select the cell to the right of "Production item", and click the [OK] button.

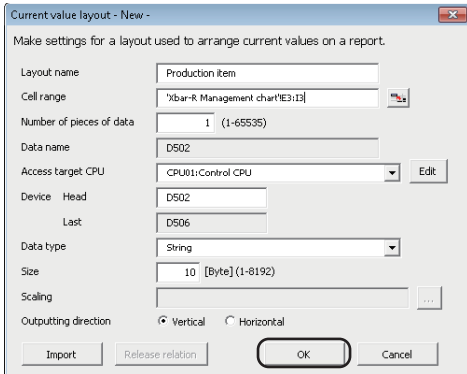

14. Click the [OK] button.

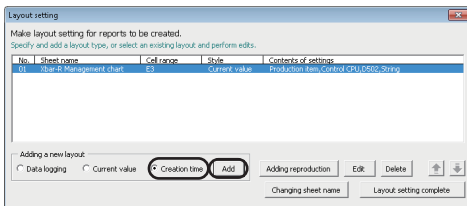

15. Select "Creation time", and click the [Add] button.

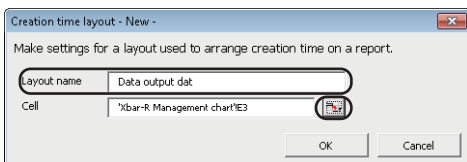

16. Enter 'Data output day' for layout name, and click the [OK] button.

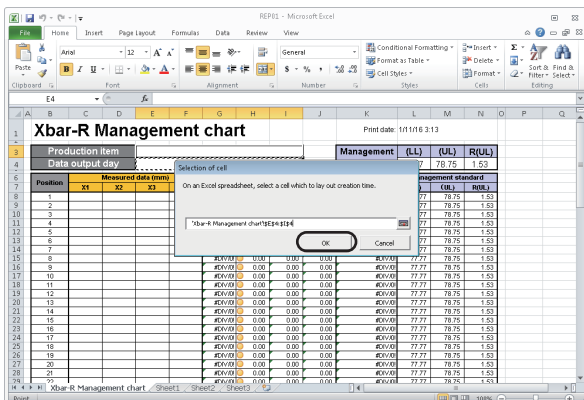

17. Select the cell to the right of "Data output day", and click the [OK] button.

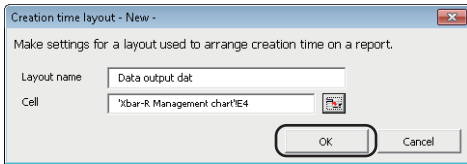

18. Click the [OK] button.

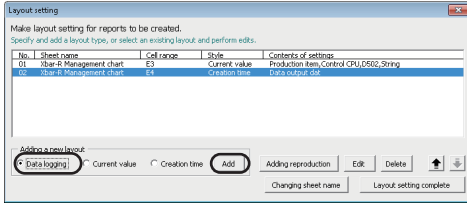

19. Select "Data logging", and click the [Add] button.

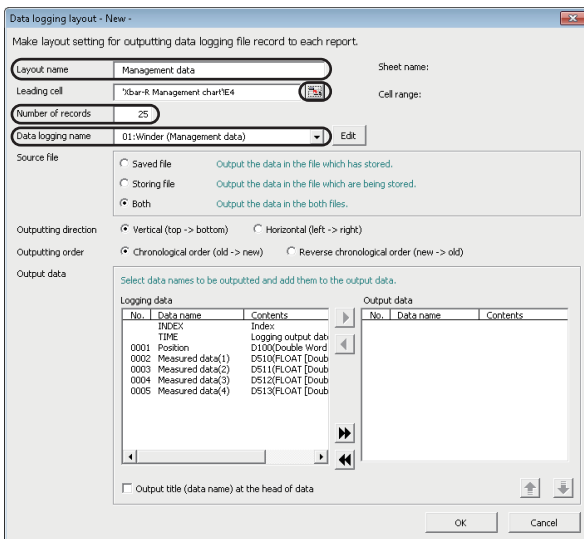

20. Set each setting item according to the following table, and click the [OK] button.

| Setting item      | Setting content             |
|-------------------|-----------------------------|
| Layout name       | Management data             |
| Number of records | 25                          |
| Data logging name | 01:Winder (Management data) |

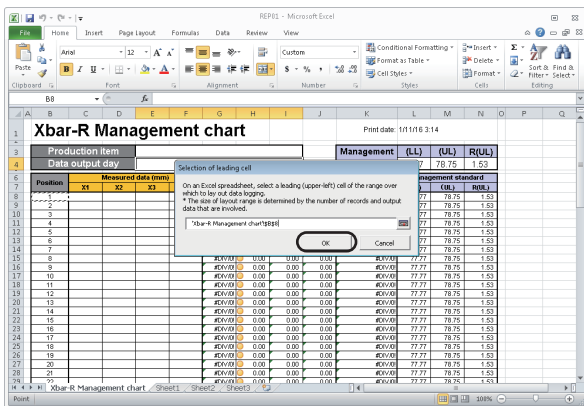

21. Select the cell under "Position", and click the [OK] button.

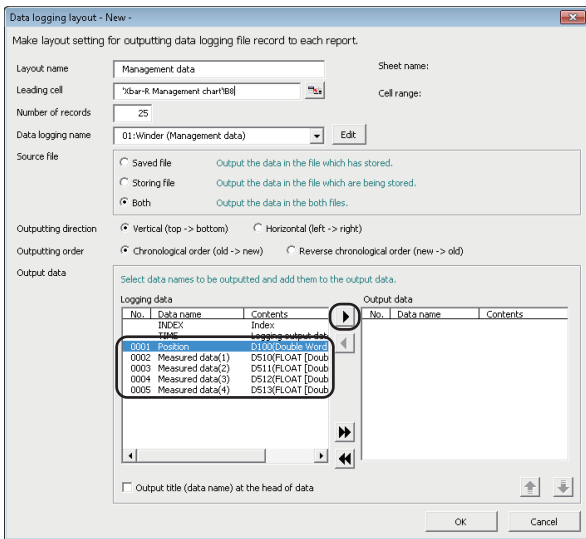

22. Select the logging data from No. 0001 to 0005 one by one, and click [▶] button. (Repeat the operation for each data.)

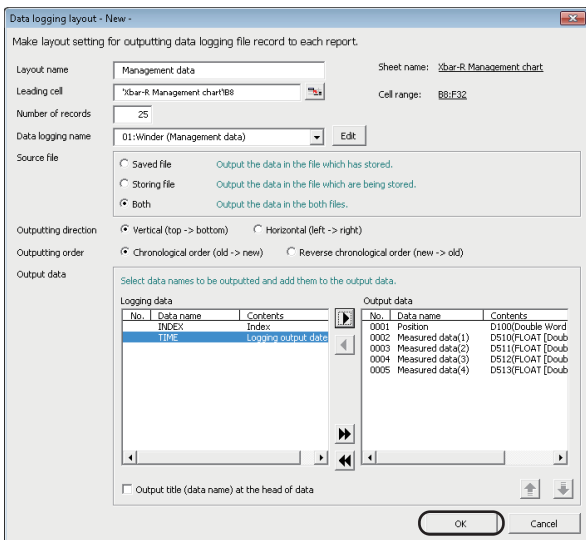

23. Click the [OK] button.

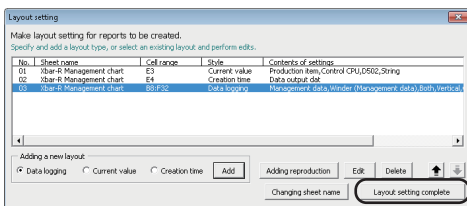

24. Click the [Layout setting complete] button.

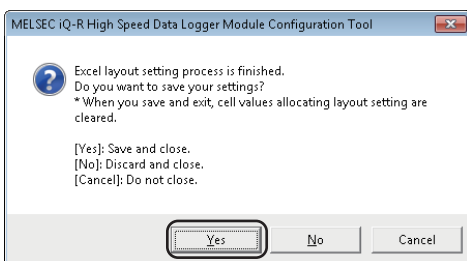

25. Click the [Yes] button.

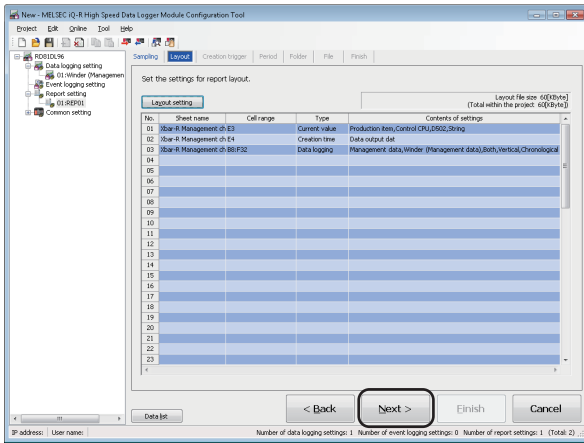

26. Click the [Next] button.

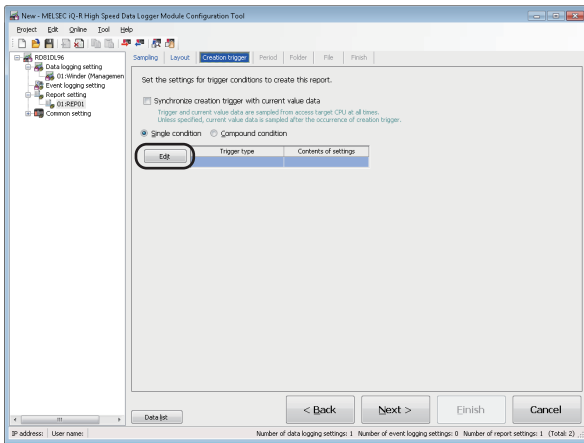

27. Click the [Edit] button.

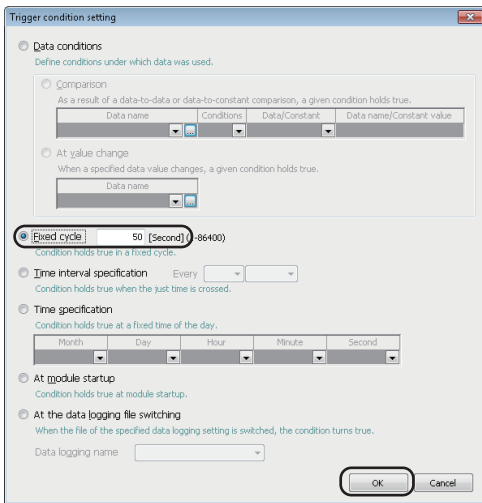

28. Select "Fixed cycle", enter '50', and click the [OK] button.

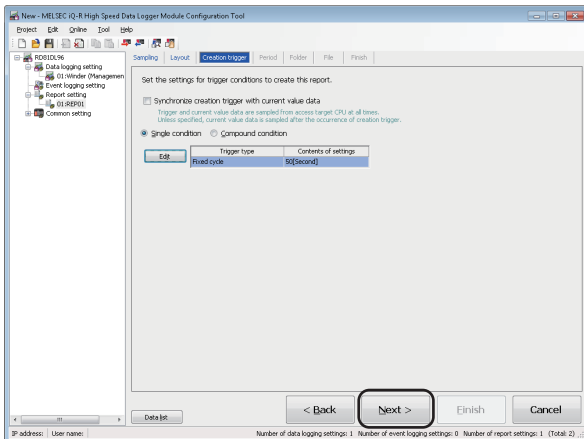

29. Click the [Next] button.

30. Click the [Next] button.

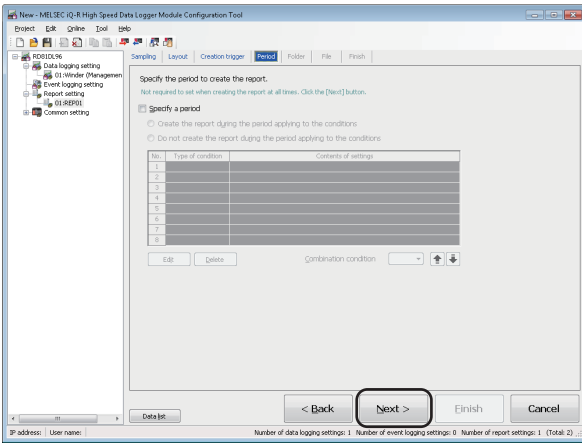

31. Enter 'Xbar-R' for the setting type folder name, and click the [Next] button.

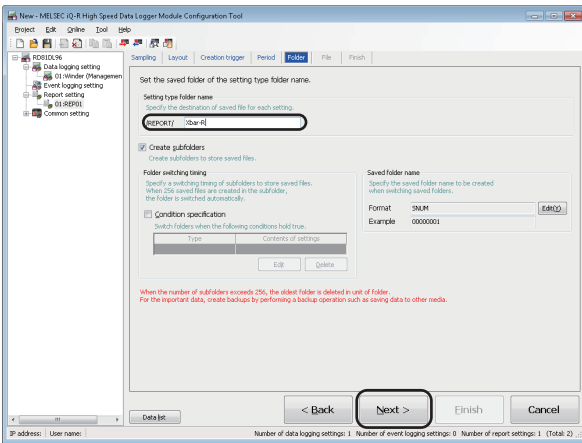

32. Enter '5' for the number of saved files, and click the [Edit] button.

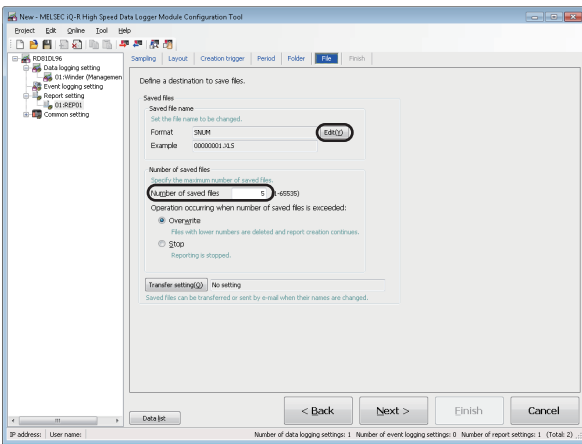

33. Select "Add the name", and click the [OK] button.

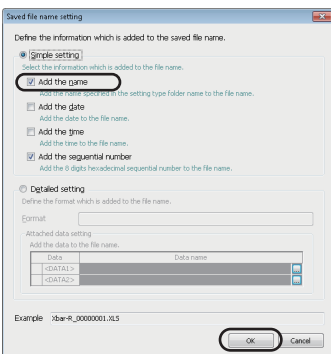

34. Click the [Next] button.

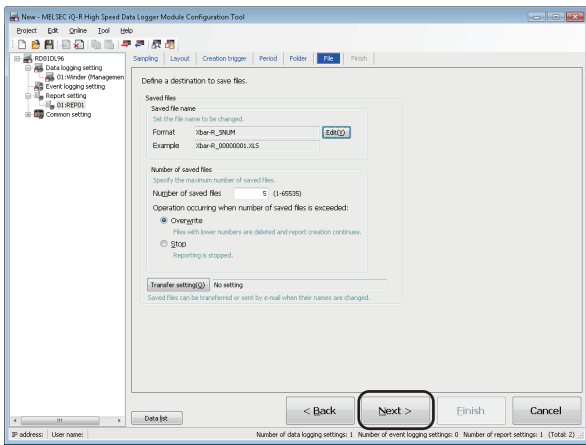

35. Enter 'Winder (Management chart)' for the report name, and click the [Finish] button.

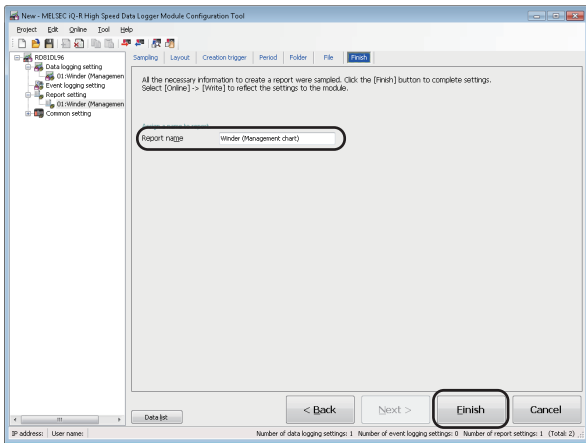

# Write settings

Write the data logging settings and the report settings to the high speed data logger module.

## Specify the target module

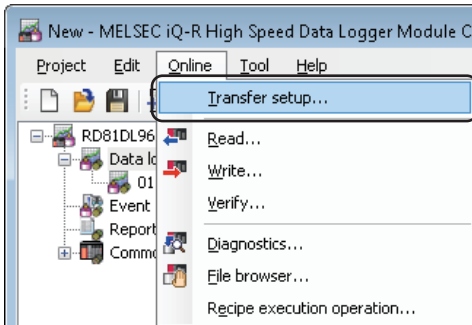

1. Select [Online] ⇒ [Transfer setup].

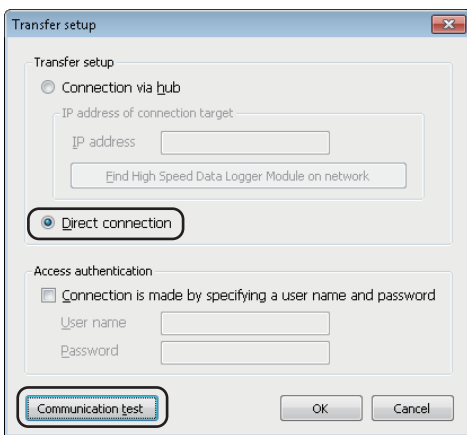

2. Select "Direct connection", and click the [Communication test] button.

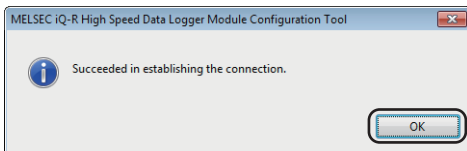

3. Click the [OK] button.

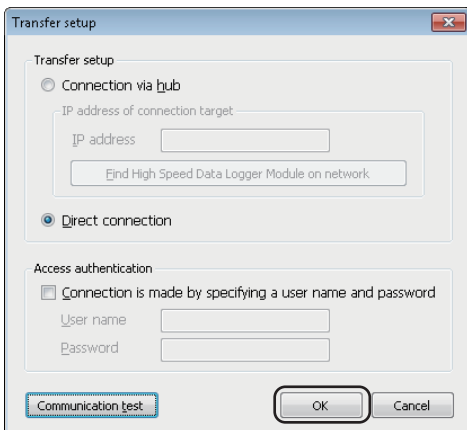

4. Click the [OK] button.

## Write the settings

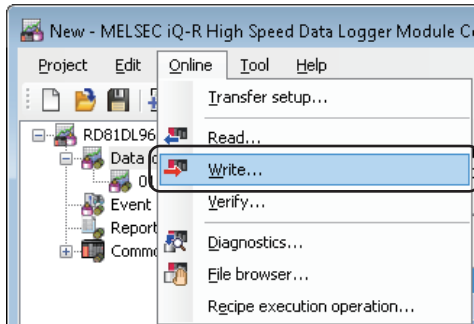

1. Select [Online] ⇒ [Write].

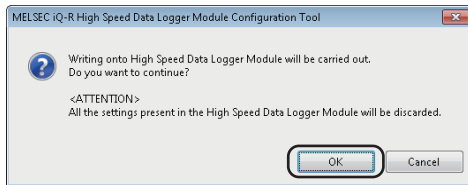

2. Click the [OK] button.

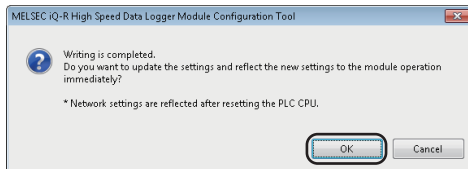

3. Click the [OK] button.

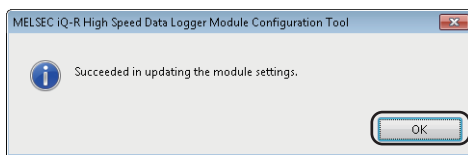

4. Click the [OK] button.



# Checking created report

Check the report created in an SD memory card which is inserted in the high speed data logger module on Excel.

## Saves the report file to a personal computer

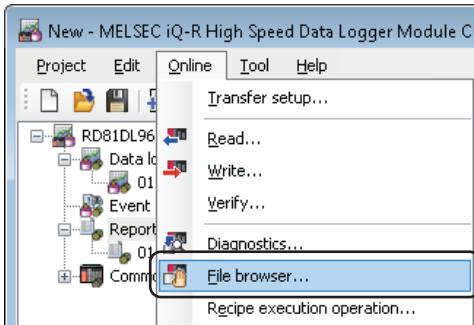

1. Select [Online] ⇒ [File browser].

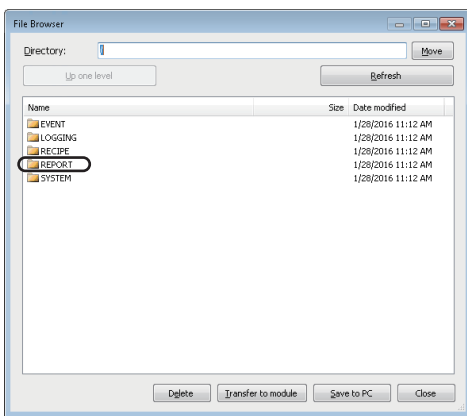

2. Double-click each folder in the following order:  
"REPORT" → "Xbar-R" → "00000001"

**Point** Click the [Refresh] button when the folder is not displayed in the list.

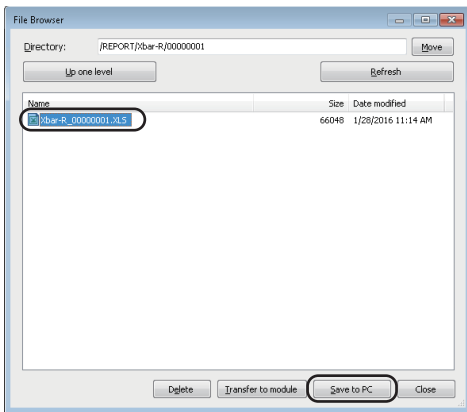

3. Select an Excel file, and click the [Save to PC] button.

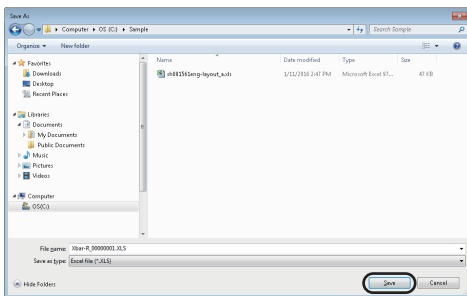

4. Specify the save destination (option), and click the [Save] button.

5. Click the [Close] button.

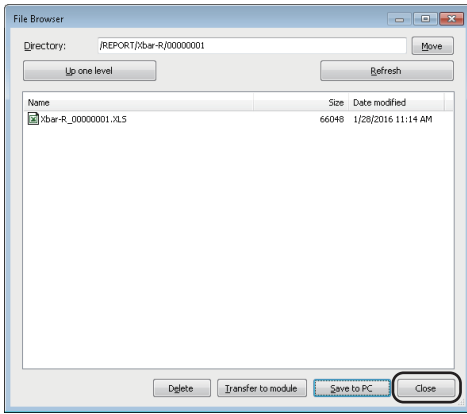

## Check a report on Excel

1. Open an Excel file saved in a personal computer.
2. Check that the logged data are applied to the table and graphs on the "Xbar-R Management chart" sheet.

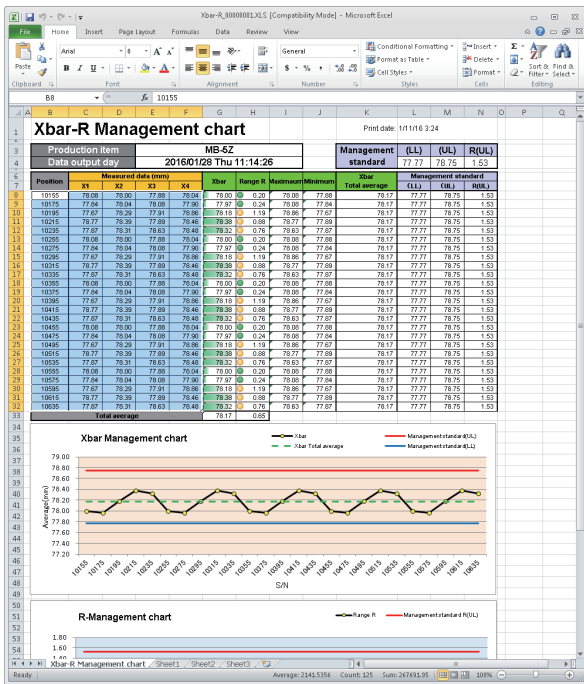



# APPENDIX

## Appendix 1 External Dimensions

The following figure shows the external dimensions of the high speed data logger module.

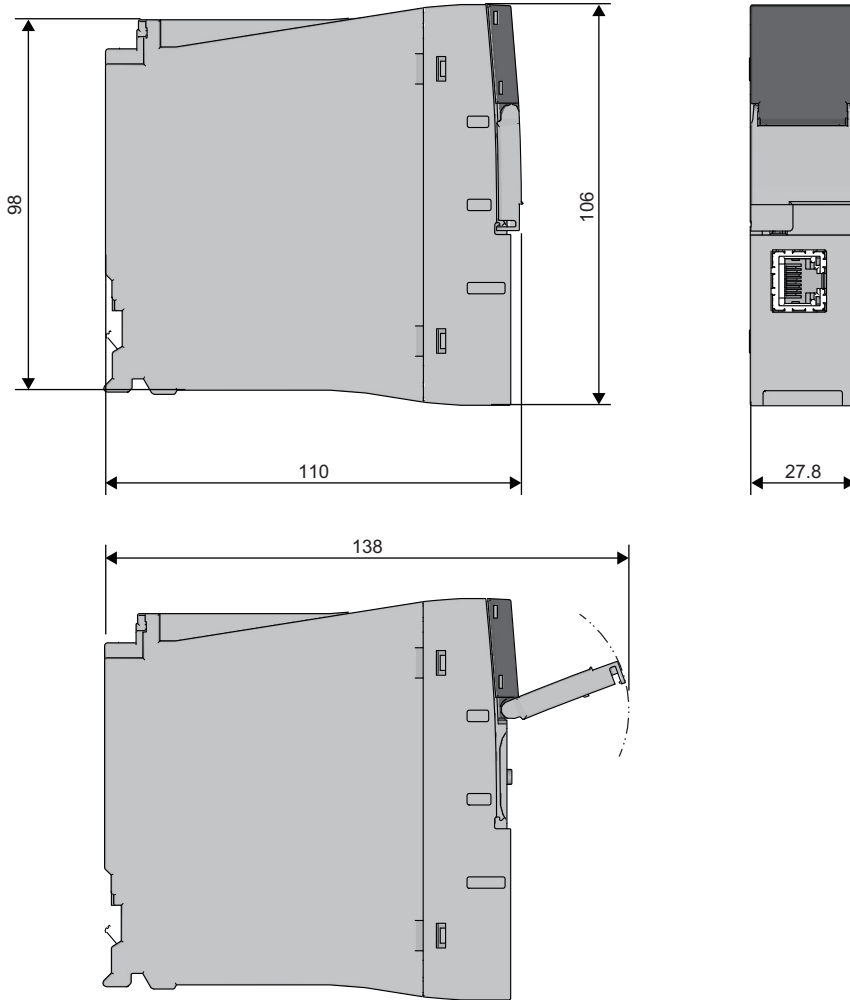

(unit : mm)

# MEMO

---

A

# INDEX

---

## A

---

|                                 |    |
|---------------------------------|----|
| Access specifications . . . . . | 33 |
| Add item . . . . .              | 59 |

## C

---

|                                       |    |
|---------------------------------------|----|
| Connection system equipment . . . . . | 71 |
|---------------------------------------|----|

## D

---

|                             |    |
|-----------------------------|----|
| Delete item . . . . .       | 59 |
| Direct connection . . . . . | 70 |

## E

---

|   |       |
|---|-------|
| Edit item tree . . . . .                | 57,59 |
| Ethernet (twisted pair) cable . . . . . | 71    |
| External dimensions . . . . .           | 114   |

## F

---

|                         |       |
|-------------------------|-------|
| FTP server . . . . .    | 67    |
| Function list . . . . . | 46,47 |

## G

---

|                            |    |
|----------------------------|----|
| General sampling . . . . . | 33 |
|----------------------------|----|

## H

---

|                               |    |
|-------------------------------|----|
| High speed sampling . . . . . | 33 |
|-------------------------------|----|

## I

---

|  |    |
|--|----|
| Inserting and removing an SD memory card . . . . . | 66 |
|--|----|

## M

---

|                       |    |
|-----------------------|----|
| Mail server . . . . . | 67 |
|-----------------------|----|

## O

---

|                           |    |
|---------------------------|----|
| Offline startup . . . . . | 52 |
| Online startup . . . . .  | 52 |

## P

---

|   |    |
|---|----|
| Parameters settings . . . . .                     | 60 |
| Performance specifications . . . . .              | 23 |
| Procedure before starting the operation . . . . . | 49 |

## S

---

|                                 |       |
|---------------------------------|-------|
| SD memory card . . . . .        | 62,71 |
| SD memory card format . . . . . | 14    |
| Shared folder . . . . .         | 67    |

# MEMO

---

# REVISIONS

\*The manual number is given on the bottom left of the back cover.

| Revision date | *Manual number     | Description   |
|---------------|--------------------|---|
| December 2015 | SH(NA)-081561ENG-A | First edition   |
| April 2016    | SH(NA)-081561ENG-B | ■Added or modified parts<br>CONSIDERATIONS FOR USE, Section 2.1, Section 3.1, Section 4.1, Section 5.3, Section 7.1 |
| December 2016 | SH(NA)-081561ENG-C | ■Added or modified parts<br>CONSIDERATIONS FOR USE, Section 2.2, Section 5.1, Section 5.3                           |
| October 2017  | SH(NA)-081561ENG-D | ■Added or modified parts<br>Section 2.1, Section 2.2  |
| July 2019     | SH(NA)-081561ENG-E | ■Added or modified parts<br>CONSIDERATIONS FOR USE, Section 2.2   |

Japanese manual number: SH-081559-E

This manual confers no industrial property rights of any other kind, nor does it confer any patent licenses. Mitsubishi Electric Corporation cannot be held responsible for any problems involving industrial property rights which may occur as a result of using the contents noted in this manual.

© 2015 MITSUBISHI ELECTRIC CORPORATION



# WARRANTY

---

Please confirm the following product warranty details before using this product.

## **1. Gratis Warranty Term and Gratis Warranty Range**

If any faults or defects (hereinafter "Failure") found to be the responsibility of Mitsubishi occurs during use of the product within the gratis warranty term, the product shall be repaired at no cost via the sales representative or Mitsubishi Service Company.

However, if repairs are required onsite at domestic or overseas location, expenses to send an engineer will be solely at the customer's discretion. Mitsubishi shall not be held responsible for any re-commissioning, maintenance, or testing on-site that involves replacement of the failed module.

[Gratis Warranty Term]

The gratis warranty term of the product shall be for one year after the date of purchase or delivery to a designated place. Note that after manufacture and shipment from Mitsubishi, the maximum distribution period shall be six (6) months, and the longest gratis warranty term after manufacturing shall be eighteen (18) months. The gratis warranty term of repair parts shall not exceed the gratis warranty term before repairs.

[Gratis Warranty Range]

- (1) The range shall be limited to normal use within the usage state, usage methods and usage environment, etc., which follow the conditions and precautions, etc., given in the instruction manual, user's manual and caution labels on the product.
- (2) Even within the gratis warranty term, repairs shall be charged for in the following cases.
  1. Failure occurring from inappropriate storage or handling, carelessness or negligence by the user. Failure caused by the user's hardware or software design.
  2. Failure caused by unapproved modifications, etc., to the product by the user.
  3. When the Mitsubishi product is assembled into a user's device, Failure that could have been avoided if functions or structures, judged as necessary in the legal safety measures the user's device is subject to or as necessary by industry standards, had been provided.
  4. Failure that could have been avoided if consumable parts (battery, backlight, fuse, etc.) designated in the instruction manual had been correctly serviced or replaced.
  5. Failure caused by external irresistible forces such as fires or abnormal voltages, and Failure caused by force majeure such as earthquakes, lightning, wind and water damage.
  6. Failure caused by reasons unpredictable by scientific technology standards at time of shipment from Mitsubishi.
  7. Any other failure found not to be the responsibility of Mitsubishi or that admitted not to be so by the user.

## **2. Onerous repair term after discontinuation of production**

- (1) Mitsubishi shall accept onerous product repairs for seven (7) years after production of the product is discontinued. Discontinuation of production shall be notified with Mitsubishi Technical Bulletins, etc.
- (2) Product supply (including repair parts) is not available after production is discontinued.

## **3. Overseas service**

Overseas, repairs shall be accepted by Mitsubishi's local overseas FA Center. Note that the repair conditions at each FA Center may differ.

## **4. Exclusion of loss in opportunity and secondary loss from warranty liability**

Regardless of the gratis warranty term, Mitsubishi shall not be liable for compensation to:

- (1) Damages caused by any cause found not to be the responsibility of Mitsubishi.
- (2) Loss in opportunity, lost profits incurred to the user by Failures of Mitsubishi products.
- (3) Special damages and secondary damages whether foreseeable or not, compensation for accidents, and compensation for damages to products other than Mitsubishi products.
- (4) Replacement by the user, maintenance of on-site equipment, start-up test run and other tasks.

## **5. Changes in product specifications**

The specifications given in the catalogs, manuals or technical documents are subject to change without prior notice.

# TRADEMARKS

---

Ethernet is a registered trademark of Fuji Xerox Co., Ltd. in Japan.

Intel is either registered trademarks or trademarks of Intel Corporation in the United States and/or other countries.

Java is registered trademarks of Oracle and/or its affiliates.

Microsoft, Windows, Excel, and Visual Basic are either registered trademarks or trademarks of Microsoft Corporation in the United States and/or other countries.

The SD and SDHC logos are trademarks of SD-3C, LLC.

The company names, system names and product names mentioned in this manual are either registered trademarks or trademarks of their respective companies.

In some cases, trademark symbols such as <sup>™</sup> or <sup>®</sup> are not specified in this manual.





SH(NA)-081561ENG-E(1907)KWIX

MODEL: RD81DL96-U-IN-E

MODEL CODE: 13JX40

## **mitsubishi electric corporation**

HEAD OFFICE : TOKYO BUILDING, 2-7-3 MARUNOUCHI, CHIYODA-KU, TOKYO 100-8310, JAPAN  
NAGOYA WORKS : 1-14, YADA-MINAMI 5-CHOME, HIGASHI-KU, NAGOYA, JAPAN

When exported from Japan, this manual does not require application to the  
Ministry of Economy, Trade and Industry for service transaction permission.

Specifications subject to change without notice.